

FIGURE 6-5-37

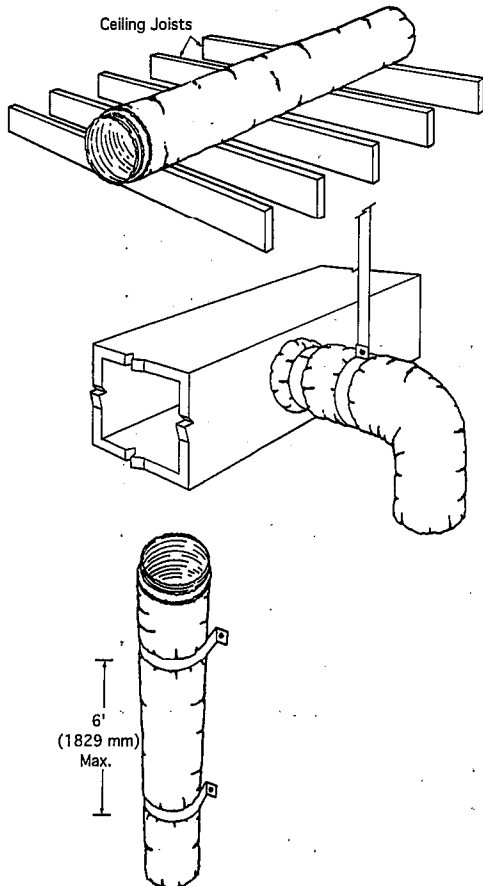

FIGURE 6-5-38 Proper Support

**A.6.510 Checklist**

The following checklist is provided for the benefit of the inspector, as well as the installer. It is designed so that the correct answer to all questions is yes.

**General**

Yes No

- Have all tears or punctures to facing material been repaired using the proper technique? ( ) ( )
- Are all sheet metal accessory items galvanized? ( ) ( )

**Product**

- Is the UL label present?  
(Although each board is labeled, each section may not be, since there is only one label per sheet.) ( ) ( )

**Fabrication and Installation**

- When metal parts are attached, are 2-1/2 inch (64 mm) minimum square steel washers used on 16-inch (406 mm) maximum centers? ( ) ( )
- When staples cannot be used, are 8 inch (203 mm) cross-tabs of approved closure being used in place of staples? ( ) ( )
- Are tab spacing requirements 12 inches, (305 mm) on center minimum one per side. ( ) ( )
- Are all system joints tight, free from bulges, with taped joints showing good workmanship? ( ) ( )
- Have offsets been installed so duct sections are not forced to bend around obstructions? ( ) ( )