

# WASHINGTON STATE BUILDING CODE

CHAPTER 51-50 WAC

## INTERNATIONAL BUILDING CODE 2006 Edition



Washington State Building Code Council

**Effective July 1, 2007**

Copies of the State Building Codes and  
complete copies of the 2006 International Building Code  
as published by the International Code Council  
may be obtained from:

Washington Association of Building Officials  
Post Office Box 7310  
Olympia, Washington 98507-7310  
(360) 586-6725      [www.wabo.org](http://www.wabo.org)  
or toll free in Washington State at (888) 664-9515

Fourth Edition Titled  
International Building Code  
Chapter 51-50 WAC  
based on  
WSR 07-01-091  
Effective July 1, 2007

## Preface

**Authority:** The International Building Code (Chapter 51-50 WAC) is adopted by the Washington State Building Code Council pursuant to Chapters 19.27 and 70.92 RCW. These codes were first adopted by reference by the Washington State Legislature in 1974. In 1985, the Legislature delegated the responsibility of adoption and amendment of these codes to the State Building Code Council.

**Code Precedence:** The State Building Code Act, Chapter 19.27 RCW, establishes the following order of precedence among the documents adopted as parts of the State Building Code:

International Building Code, Standards and amendments -WAC 51-50;  
International Residential Code, Standards and amendments – WAC 51-51;  
International Mechanical Code, Standards and amendments - WAC 51-52;  
International Fire Code, Standards and amendments - WAC 51-54;  
Uniform Plumbing Code, Standards and amendments - WAC 51-56, 51-57.

Where there is a conflict between codes, an earlier named code takes precedence over a later named code. In the case of conflict between the duct insulation requirements of the International Mechanical Code and the duct insulation requirements of the Energy Code, the Energy Code, or where applicable, a local jurisdiction's energy code, shall govern.

Where, in any specific case, different sections of this Code specify different materials, methods of construction or other requirements, the most restrictive shall govern. Where there is conflict between a general requirement and a specific requirement, the specific requirement shall be applicable.

**Organization and Numbering:** These rules are written to allow compatible use with the International Building Code. All sections which are amended, deleted, or added are referenced.

**Enforcement:** The State Building Code Act requires that each local jurisdiction enforce the State Building Code within its jurisdiction. Any jurisdiction can contract with another jurisdiction or an inspection agency to provide the mandated enforcement activities.

### **Amendments to the State Building Code:**

The State Building Code Council has adopted review procedures and approval criteria for local amendments. These procedures and criteria are found in Chapter 51-04 WAC. The Council has exempted from its review any amendments to the administrative provisions of the various codes.

Forms for proposing statewide amendments to the State Building Code are available from the State Building Code Council staff.

- A. **Amendments of Statewide Application:** On a yearly basis the State Building Code Council will consider proposals to amend the State Building Code. Unless directed by the State Legislature, federal mandates or court order, the Council will not enter formal rulemaking until 2009 as part of its consideration of adoption of the 2009 series of codes.

Proposals to amend the State Building Code shall be made on forms provided by the Building Code Council.

Code Change Proposal Submittal Deadline: March 1st of each year.

- B. **Local Amendments:** Any jurisdiction may amend the State Building Code provided the amendments do not reduce the minimum performance standards of the codes. There are two areas where local amendments are limited or prohibited:

**Prohibited Amendments:** Residential provisions of the State Energy Code (WAC 51-11), the Ventilation and Indoor Air Quality Code (WAC 51-13); any provision of the International Building Code or International Residential Code affecting accessibility; and standards specifically adopted in Chapters 19.27 and 19.27A cannot be amended by any local jurisdiction.

**Residential Amendments:** Amendments by local jurisdictions which affect the construction of single family and multi-family residential buildings must be reviewed and approved by the State Building Code Council before such amendments can be enforced. The State Building Code Act provides the following definition:

**Multi-family residential building:** means common wall residential buildings that consist of four or fewer units, that do not exceed two stories in height, that are less than 5,000 square feet in area, and that have a one-hour fire-resistive occupancy separation between units.

Application forms for Council review of local amendments are available from the State Building Code Council Staff.

Washington State Building Code Council  
Post Office Box 42525  
Olympia, Washington 98504-2525  
www.sbcc.wa.gov  
(360) 725-2966 Fax (360) 586-9383  
e-mail: sbcc@cted.wa.gov

**Printing Format:** This version of the rules is published as a series of insert or replacement pages. Each page provides instructions for installing them in the model code book. Amendments to the model code which are new or revised from the previous edition of this code are indicated by a line in the margin next to the revised portions.

**Effective Date:** These rules were adopted by the State Building Code Council on November 17, 2006. The rules are effective throughout the state on July 1, 2007. (This version of the code is based on WAC 51-50 as published in the Washington State Register. It is subject to review by the State Legislature during the 2007 session.)

**Building Permit Fees:** The activities of the State Building Code Council are supported by permit fees collected by each city and county. Section 19.27.085 of the State Building Code Act requires that a fee of \$4.50 be imposed on each building permit issued by each city and county. In addition, a fee of \$2.00 per unit shall be imposed for each dwelling unit after the first unit, on each building containing more than one residential unit. For the purpose of this fee, WAC 365-110-035 defines building permits as any permit to construct, enlarge, alter, repair, move, improve, remove, convert or demolish any building or structure regulated by the Building Code. Exempt from the fee are plumbing, electrical, mechanical permits, permits issued to install a mobile/manufactured home, commercial coach or factory built structure, or permits issued pursuant to the International Fire Code.

Each city and county shall remit moneys collected to the state treasury quarterly. No remittance is required until a minimum of \$50.00 has accumulated.

These permit fees are the amounts current in January 2007. Such fees may be changed by the State Legislature.

**Opinions:** Only at the request of local enforcement official, the State Building Code Council may issue interpretations/opinions of those provisions of the State Building Code created by the Council, or provisions of the model codes amended by the Council. final interpretation authority for any specific permit resides with the local enforcement official.

# Table of Contents

Section	Page
WAC 51-50-001	Authority ..... A
WAC 51-50-002	Purpose ..... A
WAC 51-50-003	International Building Code ..... A
WAC 51-50-004	Conflicts with Washington State Ventilation and Indoor Air Quality Code ..... A
WAC 51-50-005	International Building Code Regulations for Barrier-free Accessibility ..... A
WAC 51-50-007	Exceptions ..... A
WAC 51-50-008	Implementation ..... A
WAC 51-50-009	Recyclable Materials and Solid Waste Storage ..... A
<b>WAC 51-50-0100</b>	<b>Chapter 1 Administration</b>
WAC 51-50-0107	Section 107 – Temporary Structures and uses ..... 6
<b>WAC 51-50-0200</b>	<b>Chapter 2 Definitions</b>
WAC 51-50-0202	Section 202 – Definitions ..... 11
<b>WAC 51-50-0300</b>	<b>Chapter 3 Use and Occupancy Classification</b>
WAC 51-50-0305	Section 305 – Educational Group E ..... 24
WAC 51-50-0308	Section 308 – Institutional Group I ..... 33
WAC 51-50-0310	Section 310 – Residential Group R ..... 34
<b>WAC 51-50-0400</b>	<b>Chapter 4 Special Detailed Requirements Based on Use and Occupancy</b>
WAC 51-50-0406	Section 406 – Motor Vehicle Related Occupancies ..... 44
WAC 51-50-0407	Section 407 – Group I-2 ..... 48
<b>WAC 51-50-0500</b>	<b>Chapter 5 General Building Heights and Areas</b>
WAC 51-50-0502	Section 502 – Definitions ..... 75
WAC 51-50-0506	Section 506 – Area Modifications ..... 78
WAC 51-50-0509	Section 509 – Special Provisions ..... 82
<b>WAC 51-50-0700</b>	<b>Chapter 7 Fire-Resistance Rated Construction</b>
WAC 51-50-0707	Section 707 – Shaft Enclosures ..... 99
<b>WAC 51-50-0900</b>	<b>Chapter 9 Special Detailed Requirements Based on Use and Occupancy</b>
WAC 51-50-0902	Section 902 – Definitions ..... 173
WAC 51-50-0903	Section 903 – Automatic Sprinkler Systems ..... 174
WAC 51-50-0909	Section 909 – Smoke Control Systems ..... 192
<b>WAC 51-50-1000</b>	<b>Chapter 10 Means of Egress</b>
WAC 51-50-1008	Section 1008 – Doors, Gates and Turnstiles ..... 208
WAC 51-50-1009	Section 1009 – Stairways ..... 214
WAC 51-50-1014	Section 1014 – Exit Access ..... 218
WAC 51-50-1015	Section 1015 – Exit and Exit Access Doorways ..... 220
WAC 51-50-1017	Section 1017 – Corridors ..... 221
WAC 51-50-1019	Section 1019 – Number of Exits and Continuity ..... 223

<b>WAC 51-50-1100</b>	<b>Chapter 11 Accessibility</b>	
WAC 51-50-1101	Section 1101 – General .....	235
WAC 51-50-1106	Section 1106 – Parking and Passenger Loading Facilities .....	238
WAC 51-50-1107	Section 1107 – Dwelling Units and Sleeping Units .....	239
<b>WAC 51-50-1200</b>	<b>Chapter 12 Interior Environment</b>	
WAC 51-50-1203	Section 1203 – Ventilation .....	249
WAC 51-50-1204	Section 1204 – Temperature Control .....	250
WAC 51-50-1208	Section 1208 – Interior Space Dimensions .....	251
WAC 51-50-1210	Section 1210 – Surrounding Materials .....	252
<b>WAC 51-50-1400</b>	<b>Chapter 14 Exterior Walls</b>	
WAC 51-50-1405	Section 1405 – Installation of Wall Coverings .....	257
<b>WAC 51-50-1600</b>	<b>Chapter 16 Structural Design</b>	
WAC 51-50-1602	Section 1602 – Definitions and Notations .....	277
WAC 51-50-1607	Section 1607 – Live Loads .....	285
<b>WAC 51-50-1700</b>	<b>Chapter 17 Structural Tests and Special Inspections</b>	
WAC 51-50-1702	Section 1702 – Definitions .....	327
WAC 51-50-1714	Section 1714 – Preconstruction Load Tests .....	341
<b>WAC 51-50-2100</b>	<b>Chapter 21 Masonry</b>	
WAC 51-50-2106	Section 2106 – Working Stress Design .....	399
WAC 51-50-2108	Section 2108 – Strength Design of Masonry .....	401
WAC 51-50-2114	Section 2114 – Emission Standards .....	415
<b>WAC 51-50-2900</b>	<b>Chapter 29 Plumbing Systems</b>	
WAC 51-50-2901	Section 2901 – Plumbing Code .....	521
WAC 51-50-2902	Section 2902 – General .....	521
WAC 51-50-2903	Section 2903 – Special Provisions .....	521
<b>WAC 51-50-3000</b>	<b>Chapter 30 Elevators and Conveying Systems</b>	
WAC 51-50-3004	Section 3004 – Hoistway Venting .....	526
WAC 51-50-3006	Section 3006 – Machine Rooms .....	527
<b>WAC 51-50-3100</b>	<b>Chapter 31 Special Construction</b>	
WAC 51-50-3103	Section 3103 – Temporary Structures .....	530
WAC 51-50-3109	Section 3109 – Swimming Pool Enclosures .....	532
<b>WAC 51-50-3400</b>	<b>Chapter 34 Existing Structures</b>	
WAC 51-50-3408	Section 3408 – Moved Structures .....	543
WAC 51-50-3409	Section 3409 – Accessibility for Existing Buildings .....	544
<b>WAC 51-50-3500</b>	<b>Chapter 35 Referenced Standards</b>	
WAC 51-50-32100	Washington State Building Code Standard 31-2: Standard Test Method for Particulate Emissions from Fireplaces .....	574

<b>WAC 51-50-480000</b>	<b>Appendix M: Washington State Amendments to the 2006 International Existing Building Code</b>	
	<b>Chapter 1 Administration</b>	
WAC 51-50-480101	Section 101 – General .....	1
WAC 51-50-480102	Section 102 – Applicability .....	1
	<b>Chapter 3 Prescriptive Compliance Method</b>	
WAC 51-50-480302	Section 302 – Additions, Alterations or Repairs .....	13
WAC 51-50-480305	Section 305 – Change of Occupancy .....	15
	<b>Chapter 4 Classification of Work</b>	
WAC 51-50-480405	Section 405 – Alteration – Level 3 .....	19
	<b>Chapter 5 Repairs</b>	
WAC 51-50-480506	Section 506 – Structural .....	21
	<b>Chapter 7 Alterations—Level 2</b>	
WAC 51-50-480704	Section 704 – Fire Protection .....	31
	<b>Chapter 8 Alterations—Level 3</b>	
WAC 51-50-480807	Section 807 – Structural .....	41
	<b>Chapter 9 Change of Occupancy</b>	
WAC 51-50-480912	Section 912 – Change of Occupancy Classification .....	45
	<b>Chapter 11 Historic Buildings</b>	
WAC 51-50-481101	Section 1101 – General .....	51
WAC 51-50-481102	Section 1102 – Repairs .....	51
WAC 51-50-481103	Section 1103 – Fire Safety .....	52
WAC 51-50-481104	Section 1104 – Alterations .....	52
WAC 51-50-481105	Section 1105 – Change of Occupancy .....	53
WAC 51-50-481106	Section 1106 – Structural .....	53
	<b>Chapter 13 Performance Compliance Methods</b>	
WAC 51-50-481301	Section 1301 – General .....	57
<b>WAC 51-50-481500</b>	<b>Chapter 15 Referenced Standards .....</b>	<b>71</b>



**CHAPTER 51-50 WAC  
STATE BUILDING CODE ADOPTION AND AMENDMENT  
OF THE 2006 EDITION OF THE INTERNATIONAL BUILDING CODE**

**WAC 51-50-001 AUTHORITY**

These rules are adopted under the authority of Chapter 19.27 RCW.

**WAC 51-50-002 PURPOSE**

The purpose of these rules is to implement the provisions of Chapter 19.27 RCW, which provides that the State Building Code Council shall maintain the State Building Code in a status which is consistent with the purpose as set forth in RCW 19.27.020. In maintaining the codes the Council shall regularly review updated versions of the codes adopted under the act, and other pertinent information, and shall amend the codes as deemed appropriate by the Council.

**WAC 51-50-003 INTERNATIONAL BUILDING CODE**

The 2006 edition of the International Building Code, including Appendix E, published by the International Code Council is hereby adopted by reference with the exceptions noted in this chapter of the Washington Administrative Code.

**WAC 51-50-004 CONFLICTS WITH WASHINGTON STATE VENTILATION AND INDOOR AIR QUALITY CODE**

In the case of conflict between the ventilation requirements of Chapter 12 of this code and the ventilation requirements of Chapter 51-13 WAC, the provisions of the Ventilation and Indoor Air Quality Code shall govern.

**WAC 51-50-005 INTERNATIONAL BUILDING CODE REQUIREMENTS FOR BARRIER-FREE ACCESSIBILITY**

Chapter 11 and other International Building Code requirements for barrier-free access, including ICC A117.1-2003 and Appendix E, are adopted pursuant to Chapters 70.92 and 19.27 RCW.

Pursuant to RCW 19.27.040, Chapter 11 and requirements affecting barrier-free access shall not be amended by local governments.

**WAC 51-50-007 EXCEPTIONS**

The exceptions and amendments to the International Building Code contained in the provisions of Chapter 19.27 RCW shall apply in case of conflict with any of the provisions of these rules.

The provisions of this code do not apply to temporary growing structures used solely for the commercial production of horticultural plants including ornamental plants, flowers, vegetables, and fruits. "Temporary growing structure" means a structure that has the sides and roof covered with polyethylene, polyvinyl, or similar flexible synthetic material and is used to provide plants with either frost protection or increased heat retention. A temporary growing structure is not considered a building for purposes of this code.

The provisions of this code do not apply to the construction, alteration, or repair of temporary worker housing except as provided by rule adopted under chapter 70.114A RCW or chapter 37, Laws of 1998 (SB 6168). "Temporary worker housing" means a place, area, or piece of land where sleeping places or housing sites are provided by an employer for his or her employees or by another person, including a temporary worker housing operator, who is providing such accommodations for employees, for temporary, seasonal occupancy, and includes "labor camps" under RCW 70.54.110.

Codes referenced which are not adopted through RCW 19.27.031 or RCW 19.27A shall not apply unless specifically adopted by the authority having jurisdiction. The 2006 International Existing Buildings Code is referenced in this code as Appendix M and may be adopted by the authority having jurisdiction in accordance with Section 101.2.1.

**WAC 51-50-008 IMPLEMENTATION**

The International Building Code adopted under Chapter 51-50 WAC shall become effective in all counties and cities of this state on July 1, 2007.

**WAC 51-50-009 RECYCLABLE MATERIALS AND SOLID WASTE STORAGE**

For the purposes of this section, the following definition shall apply:

**RECYCLED MATERIALS** means those solid wastes that are separated for recycling or reuse, such as papers, metals and glass.

All local jurisdictions shall require that space be provided for the storage of recycled materials and solid waste for all new buildings

**Exceptions:** Group R-3 and Group U occupancies.

The storage area shall be designed to meet the needs of the occupancy, efficiency of pickup, and shall be available to occupants and haulers.



**107.1 General.** The building official is authorized to issue a permit for temporary structures and temporary uses. Such permits shall be limited as to time of service, but shall not be permitted for more than 180 days. The building official is authorized to grant extensions for demonstrated cause.

**Exception:** The building official may authorize unheated tents and yurts under 500 square feet accommodating an R-1 occupancy for recreational use as a temporary structure and allow them to be used indefinitely.

**(Insert Facing Page 6)**





**ADULT FAMILY HOME.** See Section 310.2

**(Insert Facing Page 11)**

**CHILD DAY CARE.** See Section 310.2

**CHILD DAY CARE HOME, FAMILY.** See Section 310.2.

**(Insert Facing Page 12)**





**NIGHTCLUB.** An establishment, other than a theater with fixed seating, which includes all of the following:

1. Provides live entertainment by paid performing artists or by way of recorded music conducted by a person employed or engaged to do so;
2. Has as its primary source of revenue the sale of beverages of any kind for consumption on the premises and/or cover charges;
3. Has an occupant load of 100 or more as determined by the fire code official; and
4. Includes assembly space without fixed seats considered concentrated or standing space per Table 1004.1.2.

Paid performing artists are those entertainers engaged to perform in a for-profit business establishment.

**PORTABLE SCHOOL CLASSROOM.** See Section 902.1

**RESIDENTIAL CARE / ASSISTED LIVING FACILITIES.** See Section 310.2. This definition is not adopted.

**(Insert Facing Page 18)**

**STORY.** That portion of a building included between the upper surface of a floor and the upper surface of the floor or roof next above, including basements (also see “Mezzanine” and Section 502.1). It is measured as the vertical distance from top to top of two successive tiers of beams or finished floor surfaces and, for the topmost story, from the top of the floor finish to the top of the ceiling joists or, where there is not a ceiling, to the top of the roof rafters.

**STORY ABOVE GRADE PLANE.** Any story having its finished floor surface entirely above grade plane, except that a basement shall be considered as a story above grade plane where the finished surface of the floor or roof next above the basement is:

1. More than 6 feet (1829 mm) above grade plane; or
2. More than 12 feet (3658 mm) above the finished ground level at any point.

**305.2 Day Care.** The use of a building or structure, or portion thereof, for educational, supervision or personal care services for more than five children older than 2-½ years of age, shall be classified as a Group E occupancy.

**Exception:** Family child day care homes licensed by the Washington State Department of Social and Health Services for the care of twelve or fewer children shall be classified as Group R-3.

(Insert Facing Page 24)





Hospitals

Nursing homes (both intermediate-care facilities and skilled nursing facilities)

Mental hospitals

Detoxification facilities

A facility such as the above with five or fewer persons shall be classified as Group R-3 or shall comply with the *International Residential Code* in accordance with Section 101.2.

A facility such as the above providing licensed care to clients in one of the categories listed in Section 310.1 regulated by either the Washington Department of Health or the Department of Social and Health Services shall be classified as Group R-2.

**308.2 Group I-1.** This occupancy shall include buildings, structures or parts thereof housing more than 16 persons, on a 24-hour basis, who because of age, mental disability or other reasons, live in a supervised residential environment that provides personal care services. The occupants are capable of responding to an emergency situation without physical assistance from staff. This group shall include, but not be limited to, the following:

Residential board and care facilities

Assisted living facilities

Halfway houses

Group homes

Congregate care facilities

Social rehabilitation facilities

Alcohol and drug centers

Convalescent facilities

A facility such as the above with five or fewer persons and adult family homes licensed by the Washington State Department of Social and Health Services shall be classified as a Group R-3 or shall comply with the *International Residential Code* in accordance with Section 101.2.

A facility such as the above providing licensed care to clients in one of the categories listed in Section 310.1 regulated by either the Washington Department of Health or the Department of Social and Health Services shall be classified as Group R-2.

**308.3 Group I-2.** This occupancy shall include buildings and structures used for medical, surgical, psychiatric, nursing or custodial care on a 24-hour basis of more than five persons who are not capable of self-preservation. This group shall include, but not be limited to, the following:

**(Insert Facing Page 33)**

**R-1** (no changes)

**R-2** Residential occupancies containing sleeping units or more than two dwelling units where the occupants are primarily permanent in nature, including:

- Apartment houses
- Boarding houses (not transient)
- Boarding homes as licensed by Department of Social and Health Services under Chapter 388-78A WAC
- Convents
- Dormitories
- Fraternities and sororities
- Hotels (nontransient)
- Monasteries
- Motels (nontransient)
- Residential treatment facilities as licensed by Department of Health under Chapter 246-337 WAC
- Vacation timeshare properties
- Congregate living facilities with 16 or fewer occupants are permitted to comply with the construction requirements for Group R-3.

**R-3** Residential occupancies where the occupants are primarily permanent in nature and not classified as R-1, R-2, R-4 or I and where buildings do not contain more than two dwelling units as applicable in Section 101.2, including adult family homes and family child day care homes for the care of twelve or fewer children, licensed by the Washington State Department of Social and Health Services, or adult and child care facilities that provide accommodations for five or fewer persons of any age for less than 24 hours. Adult family homes and family child day care homes, or adult and child care facilities that are within a single-family home are permitted to comply with the International Residential Code in accordance with Section 101.2.

Foster Family Care Homes licensed by the Washington State Department of Social and Health Services shall be permitted, as an accessory use to a dwelling, for six or fewer children including those of the resident family.

**R-4** R-4 classification is not adopted. Any reference in this code to R-4 does not apply.

**308.5.2 Child care facility.** A facility that provides supervision and personal care on a less than 24-hour basis for more than five children 2-½ years of age or less shall be classified as Group I-4.

**Exceptions:**

1. A child day care facility that provides care for more than five but no more than 100 children 2-½ years or less of age, when the rooms where such children are cared for are located on the level of exit discharge and each of these child care rooms has an exit door directly to the exterior, shall be classified as Group E.
2. Family child day care homes licensed by the Washington State Department of Social and Health Services for the care of twelve or fewer children shall be classified as Group R-3.

**310.1 Residential Group R.** Residential Group R includes, among others, the use of a building or structure, or a portion thereof, for sleeping purposes when not classified as an Institutional Group I or when not regulated by the International Residential Code in accordance with Section 101.2. Residential occupancies shall include the following:

**ADULT FAMILY HOME** means a dwelling in which a person or persons provide personal care, special care, room and board to more than one but not more than six adults who are not related by blood or marriage to the person or persons providing the services.

(Insert Facing Page 34)

**CHILD DAY CARE**, shall, for the purposes of these regulations, mean the care of children during any period of a 24 hour day.

**CHILD DAY CARE HOME, FAMILY** is a child day care facility, licensed by the state, located in the dwelling of the person or persons under whose direct care and supervision the child is placed, for the care of twelve or fewer children, including children who reside at the home.

**RESIDENTIAL CARE/ASSISTED LIVING FACILITIES.** This definition is not adopted.

⇒

**406.2.6 Floor surface.** Parking surfaces shall be of concrete or similar noncombustible and nonabsorbent materials.

**Exception:** Asphalt parking surfaces are permitted at ground level.



**(Insert Facing Page 44)**



**407.8 Locks on exit doors.** Approved, listed locks without delayed egress shall be permitted in nursing homes or portions of nursing homes, provided that:

1. The clinical needs of one or more patients require specialized security measures for their safety.
2. The doors unlock upon actuation of the automatic sprinkler system or automatic fire detection system.
3. The doors unlock upon loss of electrical power controlling the lock or lock mechanism.
4. The lock shall be capable of being deactivated by a signal from a switch located in an approved location.
5. There is a system, such as a keypad and code, in place that allows visitors, staff persons and appropriate residents to exit. Instructions for exiting shall be posted within six feet of the door.

(Insert Facing Page 48)





**STORY.** That portion of a building included between the upper surface of a floor and the upper surface of the floor or roof next above, including basements (also see “Basement” and “Mezzanine”).

**BASEMENT.** A story that is partly or completely below grade plane (see “Story above grade plane” in Section 202). A basement shall be considered as a story above grade plane where the finished surface of the floor or roof next above the basement is:

1. More than 6 feet (1829 mm) above grade plane; or
2. More than 12 feet (3658 mm) above the finished ground level at any point.

(Insert Facing Page 75)

**506.1.1 Basements.** Basements below the first story above grade plane need not be included in the total allowable area, provided each such basement does not exceed the area permitted for a building with no more than one story above grade plane.

**(Insert Facing Page 78)**



**509.2 Group S-2 enclosed or open parking garage with Group A, B, M, R or S above.** A building shall be considered as two separate and distinct buildings for the purpose of determining area limitations, continuity of fire walls, limitation of number of stories and type of construction, where all of the following conditions are met:

1. The buildings are separated with a horizontal assembly having a minimum 3-hour fire-resistance rating.
2. The building below the horizontal assembly is no more than one story above grade plane.
3. The building below the horizontal assembly is of Type IA construction.
4. Shaft, stairway, ramp and escalator enclosures through the horizontal assembly shall have not less than a 2-hour fire-resistance rating with opening protectives in accordance with Table 715.4.

**Exception:** Where the enclosure walls below the horizontal assembly have not less than a 3-hour fire-resistance rating with opening protectives in accordance with Table 715.4, the enclosure walls extending above the horizontal assembly shall be permitted to have a 1-hour fire-resistance rating, provided:

1. The building above the horizontal assembly is not required to be of Type I construction,
  2. The enclosure connects less than four stories, and
  3. The enclosure opening protectives above the horizontal assembly have a minimum 1-hour fire-protection rating.
5. The building above the horizontal assembly shall be permitted to have multiple Group A uses, each with an occupant load of less than 300, or Group B, M, R or S uses.
  6. The building below the horizontal assembly is a Group S-2 enclosed or open parking garage, used for the parking and storage of private motor vehicles.

**Exceptions:**

1. Entry lobbies, mechanical rooms and similar uses incidental to the operation of the building shall be permitted.
2. Multiple Group A uses, each with an occupant load of less than 300, or Group B or M uses shall be permitted in addition to those uses incidental to the operation of the building (including storage areas), provided that the entire structure below the horizontal assembly is protected throughout by an approved automatic sprinkler system.
7. The maximum building height in feet shall not exceed the limits set forth in Section 503 for the building having the smaller allowable height as measured from grade plane.

**509.3 Group S-2 enclosed parking garage with Group S-2 open parking garage above.** A Group S-2 enclosed parking garage with no more than one story above grade plane and located below a Group S-2 open parking garage shall be classified as a separate and distinct building for the purpose of

(Insert Facing Page 82)

determining the type of construction where the following conditions are met:

1. The allowable area of the building shall be such that the sum of the ratios of the actual area divided by the allowable area for each separate occupancy shall not exceed 1.0.
2. The Group S-2 enclosed parking garage is of Type I or II construction and is at least equal to the fire-resistance requirements of the Group S-2 open parking garage.
3. The height and number of tiers of the Group S-2 open parking garage shall be limited as specified in Table 406.3.5.
4. The floor assembly separating the Group S-2 enclosed parking garage and Group S-2 open parking garage shall be protected as required for the floor assembly of the Group S-2 enclosed parking garage. Openings between the Group S-2 enclosed parking garage and Group S-2 open parking garage, except exit openings, shall not be required to be protected.
5. The Group S-2 enclosed parking garage is used exclusively for the parking or storage of private motor vehicles, but shall be permitted to contain an office, waiting room and toilet room having a total area of not more than 1,000 square feet (93 m<sup>2</sup>), and mechanical equipment rooms incidental to the operation of the building.



(Insert Facing Page 99)

**707.14.2.1 Pressurization requirements.** Elevator hoistways shall be pressurized to maintain a minimum positive pressure of 0.10 inches of water column with respect to adjacent occupied space on all floors and a maximum pressure so as to not prevent the automatic operation of the elevator doors, as

well as accounting for the stack and wind effect expected on the mean low temperature January day. This pressure shall be measured at the midpoint of each hoistway door, with all hoistway doors open at the designated primary recall level and all other hoistway doors closed. The supply air intake shall be from an outside, uncontaminated source located a minimum distance of 20 feet from any air exhaust system or outlet.

**707.14.2.6 Elevator doors.** Each elevator door shall operate properly when hoistway pressurization is in effect.

**707.14.2.7 Hoistway venting.** Hoistway venting required by Section 3004 need not be provided for pressurized elevator shafts.

**707.14.2.8 Machine rooms.** Elevator machine rooms shall be pressurized in accordance with this section unless separated from the hoistway shaft by construction in accordance with Section 707.

**707.14.2.9 Special inspection.** Special inspection for performance shall be required in accordance with Section 909.18.8. System acceptance shall be in accordance with Section 909.19.

(Insert Facing Page 100)





**PORTABLE SCHOOL CLASSROOM.** A structure, transportable in one or more sections, which requires a chassis to be transported, and is designed to be used as an educational space with or without a permanent foundation. The structure shall be trailerable and capable of being demounted and relocated to other locations as needs arise.

**903.2.1.6 Nightclub.** An automatic sprinkler system shall be provided throughout an occupancy with a nightclub. Existing nightclubs constructed prior to July 1, 2006, shall be provided with automatic sprinklers not later than December 1, 2007. The fire code official, for the application of this rule, may establish an occupant load based on the observed use of the occupancy in accordance with Table 1004.1.2.

**903.2.2 Group E.** An automatic sprinkler system shall be provided for Group E occupancies.

**Exceptions:**

1. Portable school classrooms, provided aggregate area of any cluster or portion of a cluster of portable school classrooms does not exceed 5,000 square feet (1465 m<sup>2</sup>); and clusters of portable school classrooms shall be separated as required in Chapter 5 of the Building Code.
2. Group E occupancies with an occupant load of 50 or less.

(Insert facing page 174)

**903.2.7 Group R.** An automatic fire sprinkler system installed in accordance with Section 903.3 shall be provided throughout all buildings with a Group R fire area.

**Exception:** Group R-1 if all the following conditions apply:

1. The Group R fire area is no more than 500 square feet and is used for recreational use only.
2. The Group R fire area is only one story.
3. The Group R fire area does not include a basement.
4. The Group R fire area is no closer than 30 feet from another structure.
5. Cooking is not allowed within the Group R fire area.
6. The Group R fire area has an occupant load of no more than 8.
7. A hand held (portable) fire extinguisher is in every Group R fire area.

**909.6.3 Elevator Shaft Pressurization.** Where elevator shaft pressurization is required to comply with Exception 6 of Section 707.14.1, the pressurization system shall comply with and be maintained in accordance with Section 707.14.2.

**909.6.3.1 Activation.** The elevator shaft pressurization system shall be activated by a fire alarm system which shall include smoke detectors or other approved detectors located near the elevator shaft on each floor as approved by the building official and fire code official. If the building has a fire alarm panel, detectors shall be connected to, with power supplied by, the fire alarm panel.

**909.6.3.2 Power systems.** The power source for the fire alarm system and the elevator shaft pressurization system shall be in accordance with Section 909.11.





**1008.1.2 Door Swing.** Egress doors shall be side-hinged swinging.

**Exceptions:**

1. Private garages, office areas, factory and storage areas with an occupant load of 10 or less.
2. Group I-3 occupancies used as a place of detention.
3. Critical or intensive care patient rooms within suites of health care facilities.
4. Doors within or serving a single dwelling unit in Groups R-2 and R-3.
5. In other than Group H occupancies, revolving doors complying with Section 1008.1.3.1.
6. In other than Group H occupancies, horizontal sliding doors complying with Section 1008.1.3.3 are permitted as a means of egress.
7. Power-operated doors in accordance with Section 1008.1.3.2.
8. Doors serving a bathroom within an individual sleeping unit in Group R-1.
9. In other than Group H occupancies, manually operated horizontal sliding doors are permitted in a means of egress from occupied spaces with an occupant load of 10 or less.

Doors shall swing in the direction of egress travel where serving an occupant load of 50 or more persons or a Group H occupancy.

The opening force for interior side-swinging doors without closers shall not exceed a 5-pound force (22 N). For other side-swinging, sliding, and folding doors, the door latch shall release when subjected to a 15-pound (67 N) force. The door shall be set in motion when subjected to a 30-pound (167 N) force. The door shall swing to a full-open position when subjected to a 15-pound (67 N) force. Forces shall be applied to the latch side.

(Insert Facing Page 208)



**1009.12 Stairways in individual dwelling units.** Stairs or ladders within an individual dwelling unit used for access to areas of 200 square feet (18.6 m<sup>2</sup>) or less, and not containing the primary bathroom or kitchen, are exempt from the requirements of Section 1009.



**1014.2.2 Group I-2.** Habitable rooms or suites in Group I-2 occupancies shall have an exit access door leading directly to a corridor.

**Exception:** Rooms with exit doors opening directly to the outside at ground level. ↩

**1014.2.2.1 Definition.** For the purposes of this section, a suite is defined as a cluster of rooms or spaces sharing common circulation. Partitions within a suite are not required to have smoke or fire-resistance-rated construction unless required by another section of this Code.

**1014.2.3 Suites in patient sleeping areas.** Patient sleeping areas in Group I-2 occupancies shall be permitted to be divided into suites if one of the following conditions is met:

1. The intervening room within the suite is not used as an exit access for more than eight patient beds.
2. The arrangement of the suite allows for direct and constant visual supervision by nursing personnel.

(Continued)

(Insert Facing Page 218)

**1014.2.3.1 Area.** Suites of sleeping rooms shall not exceed 5,000 square feet (465 m<sup>2</sup>).

**1014.2.3.2 Exit access.** Any patient sleeping room, or any suite that includes patient sleeping rooms, of more than 1,000 square feet (93 m<sup>2</sup>) shall have at least two exit access doors remotely located from each other.

**1014.2.3.3 Travel distance.** The travel distance between any point in a suite of sleeping rooms and an exit access door of that suite shall not exceed 100 feet (30,480 mm).

**1014.2.4 Suites in areas other than patient sleeping areas.** Areas other than patient sleeping areas in Group I-2 occupancies shall be permitted to be divided into suites.

**1014.2.4.1 Area.** Suites of rooms, other than patient rooms, shall not exceed 10,000 square feet (929 m<sup>2</sup>).

**1014.2.4.2 Exit access.** Any rooms or suite of rooms, other than patient sleeping rooms, of more than 2,500 square feet (232 m<sup>2</sup>) shall have at least two exit access doors remotely located from each other.

**1014.2.4.3 One intervening room.** For rooms other than patient sleeping rooms, suites of rooms are permitted to have one intervening room if the travel distance within the suite is not greater than 100 feet (30,480 mm).

**1014.2.4.4 Two intervening rooms.** For rooms other than patient sleeping rooms located within a suite, exit access travel from within the suite shall be permitted through two intervening rooms where the travel distance to the exit access door is not greater than 50 feet (15,240 mm).

**1014.2.5 Travel distance.** The travel distance between any point in a Group I-2 occupancy patient room and an exit access door in that room shall not exceed 50 feet (15,240 mm).

**1014.2.6 Separation.** Suites in Group I-2 occupancies shall be separated from other portions of the building by a smoke partition complying with Section 710.

**1015.1 Exits or exit access doorways from spaces.** Two exits or exit access doorways from any space shall be provided where one of the following conditions exists:

1. The occupant load of the space exceeds one of the values in Table 1015.1.

**Exception:** One means of egress is permitted within and from dwelling units with a maximum occupant load of 20 where the dwelling unit is equipped throughout with an automatic sprinkler system in accordance with Section 903.3.1.1.

2. The common path of egress travel exceeds one of the limitations of Section 1014.3.
3. Where required by Sections 1015.3, 1015.4, 1015.5, 1015.6 or 1015.6.1.

**Exception:** Group I-2 occupancies shall comply with Section 1014.2.2.

**1015.1.1 Three or more exits or exit access doorways.** Three exits or exit access doorways shall be provided from any space with an occupant load of 501-1,000. Four exits or exit access doorways shall be provided from any space with an occupant load greater than 1,000.

(Insert Facing Page 220)

**1017.1 Construction.** Corridors shall be fire-resistance rated in accordance with Table 1017.1. The corridor walls required to be fire-resistance rated shall comply with Section 708 for fire partitions.

**Exceptions:**

1. A fire-resistance rating is not required for corridors in an occupancy in Group E where each room that is used for instruction has at least one door directly to the exterior and rooms for assembly purposes have at least one-half of the required means of egress doors opening directly to the exterior. Exterior doors specified in this exception are required to be at ground level.

(Insert Facing Page 221)

2. A fire-resistance rating is not required for corridors contained within a dwelling or sleeping unit in an occupancy in Group R.
3. A fire-resistance rating is not required for corridors in open parking garages.
4. A fire-resistance rating is not required for corridors in an occupancy in Group B which is a space requiring only a single means of egress complying with Section 1015.1.
5. In Group R-2 boarding homes and residential treatment facilities licensed by Washington state, rest areas constructed as required for corridors shall be allowed to be open to the corridor provided:
  - 5.1 The area does not exceed 150 square feet, excluding the corridor width;
  - 5.2 The floor is separated into at least two compartments complying with Section 407.4;
  - 5.3 Combustible furnishings located within the rest area shall be in accordance with the International Fire Code section 805;
  - 5.4 Emergency means of egress lighting is provided as required by Section 1006 to illuminate the area.

**1017.4 Air movement in corridors.** Corridors shall not serve as supply, return, exhaust, relief or ventilation air ducts.

**Exceptions:**

1. Use of a corridor as a source of makeup air for exhaust systems in rooms that open directly onto such corridors, including toilet rooms, bathrooms, dressing rooms, smoking lounges and janitor closets, shall be permitted provided that each such corridor is directly supplied with outdoor air at a rate greater than the rate of makeup air taken from the corridor.
2. Where located within a dwelling unit, the use of corridors for conveying return air shall not be prohibited.
3. Where located within tenant spaces of 1,000 square feet (93 m<sup>2</sup>) or less in area, utilization of corridors for conveying return air is permitted.
4. Where such air is part of an engineered smoke control system.
5. Makeup or relief air in corridors of Group 1-2 occupancies.
6. Corridors serving residential occupancies shall be permitted to be supplied without specific mechanical exhaust subject to the following:
  - 6.1 The supply air is one hundred percent outside air; and
  - 6.2 The units served by the corridor have conforming ventilation independent of the air supplied to the corridor; and
  - 6.3 For other than high-rise buildings, the supply fan will automatically shut off upon activation of corridor smoke detectors which shall be spaced at no more than thirty feet (9,144 mm) on center along the corridor; or
  - 6.4 For high-rise buildings, corridor smoke detector activation will close required smoke/fire dampers at the supply inlet to the corridor at the floor receiving the alarm.

**1017.6 Subdivision of building spaces--Smoke barriers.**

Smoke barriers complying with Section 709 shall be installed on floors other than the level of exit discharge of a Group R-2 boarding home or residential treatment facility licensed by Washington state, where a fire-resistance rated corridor is required by Table 1017.1. The smoke barrier shall subdivide the floor into at least two compartments complying with Section 407.4.

**1019.1 Exits from stories.** All spaces within each story shall have access to the minimum number of exits as specified in Table 1019.1 based on the occupant load of the story, except as modified in Section 1019.2. For the purposes of this chapter, occupied roofs shall be provided with exits as required for stories. The required number of exits from any story, including basements, shall be maintained until arrival at grade or the public way.

**Exception:** One means of egress is permitted within and from dwelling units with a maximum occupant load of 20 where the dwelling unit is equipped throughout with an automatic sprinkler system in accordance with Section 903.3.1.1.

**1019.2 Buildings with one exit.** Only one exit shall be required in buildings as specified below:

1. Buildings meeting the limitations of Table 1019.2, provided the building has not more than one level below the first story above grade plane.
2. Buildings of Group R-3 occupancy.
3. Single-level buildings with occupied spaces at the level of exit discharge provided each space complies with Section 1015.1 as a space with one exit or exit access doorway.



**1101.2 Design.** Buildings and facilities shall be designed and constructed to be accessible in accordance with this code and ICC A117.1, except those portions of ICC A117.1 amended by this section.

**1101.2.1 (ICC A117.1 Section 403) Landings for walking surfaces.** The maximum rise for any run is 30 inches (762 mm). Landings shall be provided at the top and bottom of any run. Landings shall be level and have a minimum dimension measured in the direction of travel of not less than 60 inches (1525 mm).

**1101.2.2 (ICC A117.1 Section 403.5) Clear width of accessible route.** Clear width of an accessible route shall comply with ICC A117.1 Table 403.5. For exterior routes of travel, the minimum clear width shall be 44 inches (1118 mm).

**1101.2.3 (ICC A117.1 Section 404.2.8) Door-Opening Force.** Fire doors shall have the minimum opening force allowable by the appropriate administrative authority. The force for pushing or pulling open doors other than fire doors shall be as follows:

1. Interior hinged door: 5.0 pounds (22.2 N) maximum
2. Interior sliding or folding doors: 5.0 pounds (22.2 N) maximum
3. Exterior hinged, sliding or folding door: 10 pounds (44.4 N) maximum

**Exception:** Interior or exterior automatic doors complying with Section 404.3 of ICC A117.1.

These forces do not apply to the force required to retract latch bolts or disengage other devices that hold the door in a closed position.

**1101.2.4 (ICC A117.1 Section 407.4.6.2.2) Arrangement of elevator car buttons.** This section is not adopted.

**1101.2.5 (ICC A117.1 Section 603.4) Coat hooks and shelves.** Coat hooks shall be located within one of the reach ranges specified in Section 308. Shelves shall be installed so the top of the shelf is 40 inches (1015 mm) minimum and 42 inches (1067 mm) maximum above the floor.

**1101.2.6 (ICC A117.1 Section 604.11) Coat hooks and shelves.** Coat hooks provided within toilet compartments shall be located within one of the reach ranges specified in Section 308. Shelves shall be installed so the top of the shelf is 40 inches (1015 mm) minimum and 42 inches (1067 mm) maximum above the floor.

**1101.2.7 (ICC A117.1 Section 606.7) Operable parts.** Operable parts on drying equipment, towel or cleansing product dispensers, and disposal fixtures shall comply with Table 606.7, except the maximum reach height shall be 40 inches (1015 mm) for reach depths less than 6 inches.

**1101.2.8 (ICC A117.1 Section 604.6) Flush controls.** Flush controls shall be hand operated or automatic. Hand operated flush controls shall comply with Section 309, except the maximum height above the floor shall be 44 inches (1118 mm). Flush controls shall be located on the open side of the water closet.

**Exception:** In ambulatory accessible compartments complying with Section 604.9, flush controls shall be permitted to be located on either side of the water closet.

**1101.2.9 (ICC A117.1 Section 703.6.3.1) International symbol of accessibility.** Where the International Symbol of Accessibility is required, it shall be proportioned complying with ICC A117.1 Figure 703.6.3.1. All interior and exterior signs depicting the International Symbol of Accessibility shall be white on a blue background.

**1101.2.10 (ICC A117.1 Section 404.3.5) Control switches.** Manually operated control switches shall comply with Section 309, except they shall be placed 32 inches (815 mm) minimum and 40 inches (1015 mm) maximum above the floor. The clear floor space adjacent to the control switch shall be located beyond the arc of the door swing and centered on the control switch.

accessible entrances with adjacent parking, accessible parking spaces shall be dispersed and located near the accessible entrances. Wherever practical, the accessible route shall not cross lanes of vehicular traffic. Where crossing traffic lanes is necessary, the route shall be designated and marked as a crosswalk.

**Exceptions:**

1. In multilevel parking structures, van accessible parking spaces are permitted on one level.
2. Accessible parking spaces shall be permitted to be located in different parking facilities if substantially equivalent or greater accessibility is provided in terms of distance from an accessible entrance or entrances, parking fee and user convenience.



**1106.3 Group I-1 and I-2 outpatient facilities.** Ten percent, but not less than one, of patient and visitor parking spaces provided to serve Group I-1 and I-2 outpatient facilities shall be accessible.

**1106.4 Rehabilitation facilities and outpatient physical therapy facilities.** Twenty percent, but not less than one, of the portion of patient and visitor parking spaces serving rehabilitation facilities specializing in treating conditions that affect mobility and outpatient physical therapy facilities shall be accessible.

**1106.6 Location.** Accessible parking spaces shall be located on the shortest accessible route of travel from adjacent parking to an accessible building entrance. In parking facilities that do not serve a particular building, accessible parking spaces shall be located on the shortest route to an accessible pedestrian entrance to the parking facility. Where buildings have multiple

(Insert Facing Page 238)

**1107.6 Group R.** Accessible units, Type A units and Type B units shall be provided in Group R occupancies in accordance with Sections 1107.6.1 through 1107.6.4. Accessible and Type A units shall be apportioned among efficiency dwelling units, single bedroom units and multiple bedroom units, in proportion to the numbers of such units in the building.



**1107.6.2.1.1 Type A units.** In Group R-2 occupancies containing more than 10 dwelling units or sleeping units, at least 5 percent, but not less than one, of the units shall be a Type A unit. All units on a site shall be considered to determine the total number of units and the required number of Type A units. Type A units shall be dispersed among the various classes of units.

**Exceptions:**

1. The number of Type A units is permitted to be reduced in accordance with Section 1107.7.
2. Existing structures on a site shall not contribute to the total number of units on a site.

**1107.6.2.2 Group R-2 other than apartment houses, monasteries and convents.** In Group R-2 occupancies, other than apartment houses, monasteries and convents, Accessible units and Type B units shall be provided in accordance with Sections 1107.6.2.2.1 and 1107.6.2.2.2. Accessible units shall be dispersed among the various classes of units.

(Insert Facing Page 240)





**1203.1 General.** Buildings shall be provided with natural ventilation in accordance with Section 1203.4, or mechanical ventilation in accordance with the *International Mechanical Code* and the Washington State Ventilation and Indoor Air Quality Code.

**1203.4 Natural ventilation.** For other than Group R occupancies in buildings four stories and less, natural ventilation of an occupied space shall be through windows, doors, louvers or other openings to the outdoors. The operating mechanism for such openings shall be provided with ready access so that the openings are readily controllable by the building occupants. Group R occupancies in buildings four stories and less shall comply with the Washington State Ventilation and Indoor Air Quality Code.

**1204.1 Equipment and systems.** Interior spaces intended for human occupancy shall be provided with active or passive space-heating systems capable of maintaining a minimum indoor temperature of 68°F (20°C) at a point 3 feet (914 mm) above the floor on the design heating day.

**Exceptions:**

1. Interior spaces where the primary purpose is not associated with human comfort.
2. Group R-1 occupancies not more than 500 square feet.

**1204.2 Heating.**

**1204.2.1 Definitions.** For the purposes of this section only, the following definitions apply.

**DESIGNATED AREAS** are those areas designated by a county to be an urban growth area in Chapter 36.70A RCW and those areas designated by the US Environmental Protection Agency as being in nonattainment for particulate matter.

**SUBSTANTIALLY REMODELED** means any alteration or restoration of a building exceeding 60 percent of the appraised value of such building within a 12 month period. For the purpose of this section, the appraised value is the estimated cost to replace the building and structure in kind, based on current replacement costs.

**1204.2.2 Primary Heating Source.** Primary heating sources in all new and substantially remodeled buildings in designated areas shall not be dependent upon wood stoves.

**1204.2.3 Solid Fuel Burning Devices.** No used solid fuel burning device shall be installed in new or existing buildings unless such device is United States Environmental Protection Agency certified or a pellet stove either certified or exempt from certification by the United States Environmental Protection Agency.

**Exception:** Antique wood cook stoves and heaters manufactured prior to 1940.

(Insert Facing Page 250)

**1208.2 Minimum ceiling heights.** Occupiable spaces and habitable spaces shall have a ceiling height of not less than 7 feet 6 inches (2286 mm). Bathrooms, toilet rooms, kitchens, storage rooms and laundry rooms shall be permitted to have a ceiling height of not less than 7 feet (2134 mm).

**Exceptions:**

1. In one- and two-family dwellings, beams or girders spaced not less than 4 feet (1219 mm) on center and projecting not more than 6 inches (152 mm) below the required ceiling height.
2. If any room in a building has a sloped ceiling, the prescribed ceiling height for the room is required in one-half the area thereof. Any portion of the room measuring less than 5 feet (1524 mm) from the finished floor to the ceiling shall not be included in any computation of the minimum area thereof.
3. Mezzanines constructed in accordance with Section 505.1
4. Residential Group R occupancies shall be permitted to have a ceiling height of not less than 7 feet (2134 mm).

**1208.3 Room area.** Every dwelling unit shall have at least one room that shall have not less than 120 square feet (13.9 m<sup>2</sup>) of net floor area. Other habitable rooms shall have a net floor area of not less than 70 square feet (6.5 m<sup>2</sup>).

**Exception:** Every kitchen in a one- and two-family dwelling shall have not less than 50 square feet (4.64 m<sup>2</sup>) of gross floor area.

Portions of a room with a sloped ceiling measuring less than 5 feet (1524 mm) or a flat ceiling measuring less than 7 feet (2134 mm) from the finished floor to the finished ceiling shall not be considered as contributing to the minimum habitable area for that room.

**1210.5 Toilet rooms.** This section is not adopted. (The requirements of this section have been moved to Section 2902.2.1.1)

**(Insert Facing Page 252)**





**1405.5.2 Seismic requirements.** Anchored masonry veneer located in Seismic Design Category C, D, E, or F shall conform to the requirements of Section 6.2.2.10, except Section 6.2.2.10.3.2, of the ACI 530/ASCE 5/TMS 402. |



**BALCONY, EXTERIOR.** This definition is not adopted.

**DECK.** This definition is not adopted.

**(Insert Facing Page 277)**



**IBC TABLE 1607.1**  
**MINIMUM UNIFORMLY DISTRIBUTED LIVE LOADS AND MINIMUM CONCENTRATED LIVE LOADS<sup>9</sup>**  
 (Portions of table not shown do not change)

Occupancy or Use	Uniform (psf)	Concentrated (psf)
------------------	------------------	-----------------------

5. (Reserved)		-----
---------------	--	-------

9. Decks <sup>b</sup> and Balconies	Same as occupancy served	-----
-------------------------------------	--------------------------------	-------

28. Residential		
One- and two-family dwellings		
Uninhabitable attics without storage <sup>i</sup>	10	
Uninhabitable attics with limited storage <sup>i,j,k</sup>	20	
Habitable attics and sleeping areas	30	-----
All other areas	40	
Hotels and multiple-family dwellings		
Private rooms and corridors serving them	40	
Public rooms and corridors serving them	100	

(Insert Facing Page 285)



**SMALL BUSINESS.** Any business entity (including a sole proprietorship, corporation, partnership or other legal entity) which is owned and operated independently from all other businesses, which has the purpose of making a profit, and which has fifty or fewer employees, or which has a million dollars or less per year in gross sales, of window and door products.





**1714.5 Exterior window and door assemblies.** The design pressure rating of exterior windows and doors in buildings shall be determined in accordance with Section 1714.5.1 or 1714.5.2.

**Exceptions:**

1. Structural wind load design pressures for window units smaller than the size tested in accordance with Section 1714.5.1 or 1714.5.2 shall be permitted to be higher than

**(Insert Facing Page 341)**

the design value of the tested unit provided such higher pressures are determined by accepted engineering analysis. All components of the small unit shall be the same as the tested unit. Where such calculated design pressures are used, they shall be validated by an additional test of the window unit having the highest allowable design pressure.

2. Custom exterior windows and doors manufactured by a small business shall be exempt from all testing requirements in Section 1714 of the International Building Code provided they meet the applicable provisions of Chapter 24 of the International Building Code.

**(Insert Facing Page 342)**





**2106.1.1 Basic seismic-force-resisting system.** Buildings relying on masonry shear walls as part of the basic seismic-force-resisting system shall comply with Section 1.14.2.2 of ACI 530/ASCE 5/TMS 402 or with Section 2106.1.1.1, 2106.1.1.2, or 2106.1.1.3.

**Exception:** Special reinforced masonry shear walls are not required to comply with Section 1.14.2.2.5(a) of ACI 530/ASCE 5/TMS 420 (MSJC-05), provided the masonry resists the calculated shear without shear reinforcement.



**2108.2 ACI 530/ASCE 5/TMS 402, Section 3.1.6.** Modify Section 3.1.6 as follows:

3.1.6 Headed and bent-bar anchor bolts. All embedded bolts shall be grouted in place, except that 1/4 inch (6.4 mm) diameter bolts are permitted to be placed in bed joints that are at least 1/2 inch (12.7 mm) in thickness.

(Existing Section 2108.2 and remaining sections are renumbered)



**SECTION 2114  
EMISSION STANDARDS**

**2114.1 Emission Standards for Factory-built Fireplaces.**

After January 1, 1997, no new or used factory-built fireplace shall be installed in Washington State unless it is certified and labeled in accordance with procedures and criteria specified in the Washington State Building Code Standard 31-2.

To certify an entire fireplace model line, the internal assembly shall be tested to determine its particulate matter emission performance. Retesting and recertifying is required if the design and construction specifications of the fireplace model line internal assembly change. Testing for certification shall be performed by a Washington State Department of Ecology (DOE) approved and U. S. Environmental Protection Agency (EPA) accredited laboratory.

**2114.2 Emission Standards for Certified Masonry and Concrete Fireplaces.** After January 1, 1997, new certified masonry or concrete fireplaces installed in Washington State shall be tested and labeled in accordance with procedures and criteria specified in the Washington State Building Code Standard 31-2.

To certify an entire fireplace model line, the internal assembly shall be tested to determine its particulate matter emission performance. Retesting and recertifying is required if the design and construction specifications of the fireplace model line internal assembly change. Testing for certification shall be performed by a Washington State Department of Ecology (DOE) approved and U. S. Environmental Protection Agency (EPA) accredited laboratory.

(Insert Facing Page 415)

## Chapter 29 - PLUMBING SYSTEMS

(This chapter replaces IBC Chapter 29 in its entirety)

### SECTION 2901 PLUMBING CODE

Plumbing systems shall comply with the Plumbing Code.

### SECTION 2902 GENERAL

#### 2902.1 Number of fixtures.

**2902.1.1 Requirements.** Plumbing fixtures shall be provided in the minimum number shown in Table 2902.1 and in this Chapter. Where the proposed occupancy is not listed in Table 2902.1, the building official shall determine fixture requirements based on the occupancy which most nearly resembles the intended occupancy.

Plumbing fixtures need not be provided for unoccupied buildings or facilities.

**2902.1.2 Private offices.** Fixtures only accessible to private offices shall not be counted to determine compliance with this section.

**2902.1.3 Occupancy load distribution.** The occupant load shall be divided equally between the sexes, unless data approved by the building official indicates a different distribution of the sexes.

**2902.1.4 Food preparation areas.** In food preparation, serving and related storage areas, additional fixture requirements may be dictated by health codes.

**2902.1.5 Other requirements.** For other requirements for plumbing facilities, see Section 1210 and Chapter 11.

#### 2902.2 Access to fixtures.

**2902.2.1 Location.** Plumbing fixtures shall be located in each building or conveniently in a building adjacent thereto on the same property.

**2902.2.1.1 Toilet rooms.** Toilet rooms shall not open directly into a room used for the preparation of food for service to the public or residents of Group R-2 boarding homes and residential treatment facilities licensed by Washington State.

**2902.2.2 Multiple tenants.** Access to toilets serving multiple tenants shall be through a common use area and not through an area controlled by a tenant.

**2902.2.3 Multistory buildings.** Required fixtures shall not be located more than one vertical story above or below the area served.

#### 2902.3 Separate facilities.

**2902.3.1 Requirements.** Separate toilet facilities shall be provided for each sex.

**Exception:** In occupancies serving 15 or fewer persons, one toilet facility designed for use by no more than one person at a time shall be permitted for use by both sexes.

**2902.3.2 Food service establishments.** When customers and employees share the same facilities, customers accessing the facilities are excluded from food preparation and storage areas.

**2902.4 Pay facilities.** Required facilities shall be free of charge. Where pay facilities are installed, they shall be in addition to the minimum required facilities.

**2902.5** is not adopted.

### SECTION 2903 SPECIAL PROVISIONS

**2903.1 Dwelling units.** Dwelling units shall be provided with a kitchen sink.

**2903.2 Water closet space requirements.** The water closet stool in all occupancies shall be located in a clear space not less than 30 inches (762 mm) in width, with a clear space in front of the stool of not less than 24 inches (610 mm).

**2903.3 Water.** Each required sink, lavatory, bathtub and shower stall shall be equipped with hot and cold running water necessary for its normal operation.

#### 2903.4 Drinking fountains.

**2903.4.1 Number.** Occupant loads over 30 shall have one drinking fountain for the first 150 occupants, then one per each additional 500 occupants.

##### Exceptions:

1. Sporting facilities with concessions serving drinks shall have one drinking fountain for each 1000 occupants.
2. A drinking fountain need not be provided in a drinking or dining establishment.

**2903.4.2 Multistory buildings.** Drinking fountains shall be provided on each floor having more than 30 occupants in schools, dormitories, auditoriums, theaters, offices and public buildings.

**2903.4.3 Penal Institutions.** Penal institutions shall have one drinking fountain on each cell block floor and one on each exercise floor.

**2903.4.4 Location.** Drinking fountains shall not be located in toilet rooms.

(Insert Replacing Page 521)

**TABLE 2902.1 – MINIMUM PLUMBING FIXTURES 1,2,4,6**

TYPE OF BUILDING OR OCCUPANCY <sup>8</sup>	WATER CLOSETS (fixtures per person)		LAVATORIES <sup>9</sup> (fixtures per person)		BATHTUB OR SHOWER (fixtures per person)
	MALE <sup>3</sup>	FEMALE	MALE	FEMALE	
For the occupancies listed below, use 30 square feet (2.79 m <sup>2</sup> ) per occupant for the minimum number of plumbing fixtures.					
<b>Group A</b> Assembly places -- Conference rooms, dining rooms, drinking establishments, exhibit rooms, gymnasiums, lounges, stages and similar uses including restaurants classified as Group B occupancies	1:1-25 2:26-75 3:76-125 4:126-200 5:201-300 6:301-400 Over 400, add one fixture for each additional 200 males or 150 females.	1:1-25 2:26-75 3:76-125 4:126-200 5:201-300 6:301-400	one per 2 water closets		
For the assembly occupancies listed below, use the number of fixed seating or, where no fixed seating is provided, use 15 square feet (1.39 m <sup>2</sup> ) per occupant for the minimum number of plumbing fixtures.					
Assembly places <sup>9</sup> -- Theaters, auditoriums, convention halls, dance floors, lodge rooms, casinos, and such places which have limited time for fixture use (intermissions)	1:1-100 2:101-200 3:201-400 Over 400, add one fixture for each additional 250 males or 50 females.	One per 25 up to 400	1:1-200 2:201-400 3:401-750 Over 750, add one fixture for each additional 500 persons.	1:1-200 2:201-400 3:401-750	
Assembly places -- Stadiums, arena and other sporting facilities where fixture use is not limited to intermissions.	1:1-100 2:101-200 3:201-400 Over 400, add one fixture for each additional 300 males or 100 females.	One per 50 up to 400	1:1-200 2:201-400 3:401-750 Over 750, add one fixture for each additional 500 persons.	1:1-200 2:201-400 3:401-750	
For the assembly occupancies listed below, use the number of fixed seating or, where no fixed seating is provided, use 30 square feet (2.79 m <sup>2</sup> ) per occupant for the minimum number of plumbing fixtures.					
Worship places Principal assembly area Educational & activity unit	one per 150 one per 125	one per 75 one per 75	one per 2 water closets one per 2 water closets		
For the occupancies listed below, use 200 square feet (18.58 m <sup>2</sup> ) per occupant for the minimum number of plumbing fixtures					
<b>Group B</b> and other clerical or administrative employee accessory use	1:1-15 2:16-35 3:36-55 Over 55, add one for each additional 50 persons.	1:1-15 2:16-35 3:36-55	one per 2 water closets		
For the occupancies listed below, use 100 square feet ( 9.3 m <sup>2</sup> ) per student for the minimum number of plumbing fixtures.					
<b>Group E</b> Schools -- for staff use All schools (One staff per 20 students)  Schools -- for student use Day care  Elementary Secondary	1:1-15 2:16-35 3:36-55 Over 55, add one fixture for each additional 40 persons.  1:1-20 2:21-50 Over 50, add one fixture for each additional 50 persons.  one per 30 one per 40	1:1-15 2:16-35 3:36-55  1:1-20 2:21-50  one per 25 one per 30	one per two water closets  1:1-20 2:21-50 Over 50, add one fixture for each additional 50 persons.  one per two water closets one per two water closets		

**TABLE 2902.1 – MINIMUM PLUMBING FIXTURES 1,2,4,6**  
(Continued)

TYPE OF BUILDING OR OCCUPANCY <sup>8</sup>	WATER CLOSETS (fixtures per person)		LAVATORIES <sup>5</sup> (fixtures per person)		BATHTUB OR SHOWER (fixtures per person)
	MALE <sup>3</sup>	FEMALE	MALE	FEMALE	
For the occupancies listed below, use 50 square feet (4.65 m <sup>2</sup> ) per occupant for the minimum number of plumbing fixtures.					
<b>Education Facilities other than Group E</b> Others (colleges, universities, adult centers, etc.)	one per 40	one per 25	one per two water closets		
For the occupancies listed below, use 2,000 square feet (185.8 m <sup>2</sup> ) per occupant for the minimum number of plumbing fixtures.					
<b>Group F and Group H</b> Workshop, foundries and similar establishments, and hazardous occupancies	1:1-10 2:11-25 3:26-50 4:51-75 5:76-100 Over 100, add one fixture for each additional 30 persons.	1:1-10 2:11-25 3:26-50 4:51-75 5:76-100	one per two water closets		one shower for each 15 persons exposed to excessive heat or to skin contamination with irritating materials
For the occupancies listed below, use the designated application and 200 square feet (18.58 m <sup>2</sup> ) per occupant of the general use area for the minimum number of plumbing fixtures.					
<b>Group I</b> <sup>7</sup> Hospital waiting rooms  Hospital general use areas	one per room (usable by either sex)  1:1-15 2:16-35 3:36-55 Over 55, add one fixture for each additional 40 persons.	1:1-15 3:16-35 4:36-55	one per room  one per two water closets		
<b>Hospital patient rooms:</b> Single Bed  Isolation  Multi-Bed Long-term	one adjacent to and directly accessible from  one adjacent to and directly accessible from  one per four patients one per four patients		one per toilet room  one per toilet room  one per four patients one per four patients		one per toilet room  one per toilet room  one per eight patients one per 15 patients
<b>Jails and reformatories</b> Cell Exercise room	one per cell one per exercise room		one per cell one per exercise room		
<b>Other institutions</b> (on each occupied floor)	one per 25	one per 25	one per two water closets		one per eight
For the occupancies listed below, use 200 square feet (18.58 m <sup>2</sup> ) per occupant for the minimum number of plumbing fixtures.					
<b>Group M</b> Retail or wholesale stores	1:1-50 2:51-100 3:101-400  Over 400, add one fixture for each additional 300 males or 150 females.	1:1-50 2:51-100 3:101-200 4:201-300 5:301-400	one per two water closets		



**TABLE 2902.1 – MINIMUM PLUMBING FIXTURES <sup>1,2,4,6</sup>**  
(Continued)

TYPE OF BUILDING OR OCCUPANCY <sup>8</sup>	WATER CLOSETS (fixtures per person)		LAVATORIES <sup>5</sup> (fixtures per person)		BATHTUB OR SHOWER (fixtures per person)
	MALE <sup>3</sup>	FEMALE	MALE	FEMALE	
For Group R occupancies containing dwelling units or guest rooms, use the table below. For dormitories, use 200 square feet (18.58 m <sup>2</sup> ) per occupant for the minimum number of plumbing fixtures.					
<b>Group R</b>					
Dwelling units	one per dwelling unit		one per dwelling unit		one per dwelling unit
Hotel, Motel, and Boarding house guest rooms	one per guest room		one per guest room		one per guest room
Boarding homes licensed by the Department of Social and Health Services	one per 8	one per 8	one per 8	one per 8	one per 12
Dormitories	one per 10 Over 10, add one fixture for each additional 25 males and over 8, add one for each additional 20 females.	one per 8	one per 12 over 12, add one fixture for each additional 20 males and one for each additional 15 females.	one per 12	one per eight For females, add one additional unit per each additional 30. Over 150 persons, add one additional unit per each additional 20 persons.
For the occupancies listed below, use 5,000 square feet (464.5 m <sup>2</sup> ) per occupant for the minimum number of plumbing fixtures.					
<b>Group S</b>					
Warehouses	1:1-10 2:11-25 3:26-50 4:51-75 5:76-100 Over 100, add one for each 30 persons.	1:1-10 2:11-25 3:26-50 4:51-75 5:76-100	One per 40 occupants of each sex.		one shower for each 15 persons exposed to excessive heat or to skin contamination with poisonous, infectious or irritating materials.

<sup>1</sup>The figures shown are based on one fixture being the minimum required for the number of persons indicated or any fraction thereof.

<sup>2</sup>For occupancies not shown, see Section 2902.1.1.

<sup>3</sup>Where urinals are provided, one water closet less than the number specified may be provided for each urinal installed, except the number of water closets in such cases shall not be reduced to less than one quarter (25%) of the minimum specified. For men's facilities serving 26 or more persons, not less than one urinal shall be provided.

<sup>4</sup>For drinking fountains, see Section 2903.4.

<sup>5</sup>Twenty-four inches (610 mm) of wash sink or 18 inches (457 mm) of a circular basin, when provided with water outlets for such space, shall be considered equivalent to one lavatory.

<sup>6</sup>For when a facility may be usable by either sex, see Section 2902.3.1.

<sup>7</sup>See WAC 246-320 for definitions, other fixtures and equipment for hospitals.

<sup>8</sup>When a space is accessory to or included as a part of a different occupancy group per Chapter 3, the area per occupant for the minimum plumbing fixture number is to be determined by its own specific use or purpose, not by that of the building's occupancy group.

<sup>9</sup>In multiplex movie theaters, where shows are scheduled at different times, the number of occupants for toilet fixture use may be based upon one-half (50%) of the total in all the auditoriums, but no less than the number in the largest auditorium.

**3004.3 Area of vents.** Except as provided for in Section 3004.3.1, the area of the vents shall not be less than 3-1/2 percent of the area of the hoistway nor less than 3 square feet (0.28m<sup>2</sup>) for each elevator car, and not less than 3-1/2 percent nor less than 0.5 square feet (0.047 m<sup>2</sup>) for each dumbwaiter car in the hoistway, whichever is greater. The total required vent area shall be equipped with dampers that remain powered closed until activated open by the fire alarm system panel. The dampers shall open upon loss of power.

(Insert Facing Page 526)

**3006.2 Venting.** Machinery spaces, machine rooms, control spaces, and control rooms that contain solid-state equipment for elevator operation shall be provided with an independent ventilation or air-conditioning system to protect against the overheating of the electrical equipment. Ventilation systems shall use outdoor makeup air. The system shall service the equipment space only, and shall be capable of maintaining the temperature and humidity within the range established by the manufacturer's specifications. Where no manufacturer specifications are available, the equipment space temperature shall be maintained at no less than 55°F and no more than 90°F.

The cooling load for the equipment shall include the BTU output of the elevator operation equipment as specified by the manufacturer based on one hour of continuous operation. The outdoor design temperature for ventilation shall be from the 0.5% column for summer from the Puget Sound Chapter of ASHRAE publication "*Recommended Outdoor Design Temperatures, Washington State.*" The following formula shall be used to calculate flow rate for ventilation:

$$\text{CFM} = \text{BTU output of elevator machine room equipment} / [1.08 \times (\text{acceptable machine room temp} - \text{makeup air temp})]$$

**Exception:** For buildings four stories or less, natural or mechanical means may be used in lieu of an independent ventilation or air-conditioning system to keep the equipment space ambient air temperature and humidity in the range specified by the elevator equipment manufacturer.



(Insert Facing Page 527)

**3103.1 General.** The provisions of this section shall apply to structures erected for a period of less than 180 days. Tents and other membrane structures erected for a period of less than 180 days shall comply with the International Fire Code. Those erected for a longer period of time shall comply with the applicable sections of this code.

**Exception:** The building official may authorize unheated tents and yurts under 500 square feet accommodating an R-1 occupancy for recreational use as a temporary structure and allow them to be used indefinitely.

(Insert Facing Page 530)



**3109.3 Public swimming pools.** This section is not adopted. Public swimming pools barriers are regulated by WAC 246-260-031(4).

**(Insert Facing Page 532)**





**3408.1 Conformance.** Buildings or structures moved into or within the jurisdiction shall comply with the provisions of this code, the International Residential Code (WAC 51-51), the International Mechanical Code (WAC 51-52), the International Fire Code (WAC 51-54), the Uniform Plumbing Code and Standards (WAC 51-56 and 51-57), the Washington State Energy Code (WAC 51-11) and the Washington State Ventilation and Indoor Air Quality Code (WAC 51-13) for new buildings or structures.

**Exception:** Group R-3 buildings or structures are not required to comply if:

1. The original occupancy classification is not changed, and
2. The original building is not substantially remodeled or rehabilitated.

For the purposes of this section a building shall be considered to be substantially remodeled when the costs of remodeling exceed 60 percent of the value of the building exclusive of the costs relating to preparation, construction, demolition or renovation of foundations.

installation or alteration of fire protection systems and abatement of hazardous materials.

4. This provision does not apply to alterations undertaken for the primary purpose of increasing the accessibility of an existing building, facility or element.



**3409.7 Alterations affecting an area containing a primary function.** Where an alteration affects the accessibility to, or contains an area of primary function, the route to the primary function area shall be accessible. The accessible route to the primary function area shall include toilet facilities, telephones or drinking fountains serving the area of primary function.

**Exceptions:**

1. The costs of providing the accessible route are not required to exceed 20 percent of the costs of the alteration affecting the area of primary function.
2. This provision does not apply to alterations limited solely to windows, hardware, operating controls, electrical outlets and signs.
3. This provision does not apply to alterations limited solely to mechanical systems, electrical systems,

**3409.8.9 Toilet rooms.** Where it is technically infeasible to alter existing toilet and bathing facilities to be accessible, an accessible unisex toilet or bathing facility is permitted. The unisex facility shall be located on the same floor and in the same area as the existing facility. The number of toilet facilities and water closets required by the State Building Code is permitted to be reduced by one, in order to provide accessible features.



**(Insert Facing Page 544)**



**WAC 51-50-31200****Washington State Building Code Standard 31-2  
STANDARD TEST METHOD FOR PARTICULATE EMISSIONS FROM FIREPLACES**

See Section 2114, International Building Code

*(Insert Following Page 596)***SECTION 31.200 — TITLE and SCOPE****SECTION 31.200.1 TITLE**

This Appendix Chapter 31-2 shall be known as the "Washington State Standard Test Method for Particulate Emissions from Fireplaces" and may be cited as such; and will be referred to herein as "this Standard".

**SECTION 31.200.2 SCOPE**

This Standard covers emissions performance, approval/certification procedures, test laboratory accreditation, record keeping, reporting requirements, and the test protocol for measuring particulate emissions from fireplaces.

All testing, reporting and inspection requirements of this Standard shall be conducted by a Washington State Department of Ecology (DOE) approved testing laboratory. In order to qualify for DOE approval, the test laboratory must be a U. S. Environmental Protection Agency (EPA) accredited laboratory (40 CFR Part 60, Subpart AAA). DOE may approve a test laboratory upon submittal of the following information:

1. A copy of their U. S. EPA accreditation certificate; and
2. A description of their facilities, test equipment, and test-personnel qualifications including education and work experience.

DOE may revoke a test laboratory approval when the test laboratory is no longer accredited by the U. S. EPA or if DOE determines that the test laboratory does not adhere to the testing requirements of this Chapter.

**SECTION 31.201 — DEFINITIONS**

For the purpose of this Standard certain terms are defined as follows:

**ANALYZER CALIBRATION ERROR** is the difference between the gas concentration exhibited by the gas analyzer and the known concentration of the calibration gas when the calibration gas is introduced directly to the analyzer.

**BURN RATE** is the average rate at which test-fuel is consumed in a fireplace measured in kilograms of wood (dry basis) per hour (kg/hr) during a test-burn.

**CALIBRATION DRIFT** is the difference in the analyzer reading from the initial calibration response at a mid-range calibration value after a stated period of operation during which no unscheduled maintenance, repair, or adjustment took place.

**CALIBRATION GAS** is a known concentration of Carbon Dioxide (CO<sub>2</sub>), Carbon Monoxide (CO), or Oxygen (O<sub>2</sub>) in Nitrogen (N<sub>2</sub>).

**CERTIFICATION or AUDIT TEST** is the completion of at least one, three-fuel-load test-burn cycle in accordance with Section 31.202.

**FIREBOX** is the chamber in the fireplace in which a test-fuel charge(s) is placed and combusted.

**FIREPLACE** is a wood burning device which is exempt from U. S. EPA 40 CFR Part 60, Subpart AAA and:

1. is not a cookstove, boiler, furnace, or pellet stove as defined in 40 CFR Part 60, Subpart AAA, and
2. is not a masonry heater as defined in Section 31.201.

**FIREPLACE, CERTIFIED**, is a fireplace that meets the emission performance standards when tested according to Washington State Building Code Standard 31-2.

**FIREPLACE, NON-CERTIFIED**, (masonry or concrete) is any fireplace that is not a certified fireplace. A non-certified fireplace will be subject to applicable burn ban restrictions.

**FIREPLACE DESIGN** is the construction and/or fabrication specifications including all dimensions and materials required for manufacturing or building fireplaces with identical combustion function and particulate emissions factors.

**FIREPLACE MODEL LINE** is a series of fireplace models which all have the same internal assembly. Each model in a model line may have different facade designs and external decorative features.

**INTERNAL ASSEMBLY** is the core construction and firebox design which produces the same function and emissions factor for a fireplace model line.

**(Insert as Page 574a)**

**MASONRY HEATER** is a heating system of predominantly masonry construction having a mass of at least 800 kg (1760 lbs), excluding the chimney and foundation, which is designed to absorb a substantial portion of the heat energy from a rapidly-burned charge of solid fuel by:

- a) routing of exhaust gases through internal heat exchange channels in which the flow path downstream of the firebox includes at least one 180 degree change in flow direction, usually downward, before entering the chimney, and
- b) being constructed of sufficient mass such that under normal operating conditions the external surface of the heater, except in the region immediately surrounding the fuel loading door(s), does not exceed 110°C (230°F).

Masonry heaters shall be listed or installed in accordance with ASTM E-1602.

**RESPONSE TIME** is the amount of time required for the measurement system to display 95 percent of a step change in gas concentration.

**SAMPLING SYSTEM BIAS** is the difference between the gas concentrations exhibited by the analyzer when a known concentration gas is introduced at the outlet of the sampling probe and when the sample gas is introduced directly to the analyzer.

**SPAN** is the upper limit of the gas concentration measurement range (25 percent for CO<sub>2</sub>, O<sub>2</sub>, and 5 percent for CO).

**TEST FACILITY** is the area in which the fireplace is installed, operated, and sampled for emissions.

**TEST FUEL LOADING DENSITY** is the weight of the as-fired test-fuel charge per unit area of usable firebox floor (or hearth).

**TEST-BURN** is an individual emission test which encompasses the time required to consume the mass of three consecutively burned test-fuel charges.

**TEST-FUEL CHARGE** is the collection of test fuel pieces placed in the fireplace at the start of certification test.

**USABLE FIREBOX AREA** is the floor (or hearth) area, within the fire chamber of a fireplace upon which a fire may be, or is intended to be built. Usable firebox area is calculated using the following definitions:

1. Length. The longest horizontal fire chamber dimension along the floor of the firebox that is parallel to a wall of the fire chamber.
2. Width. The shortest horizontal fire chamber dimension along the floor of the firebox that is parallel to a wall of the fire chamber.

3. For angled or curved firebox walls and/or sides, the effective usable firebox area shall be determined by calculating the sum of standard geometric areas or sub-areas of the firebox floor.

If a fireplace has a floor area within the fire chamber which is larger than the area upon which it is intended that fuel be placed and burned, the usable firebox area shall be calculated as the sum of standard geometric areas or sub-areas of the area intended for fuel placement and burning. For fireplace grates which elevate the fuel above the firebox floor, usable firebox area determined in this manner shall be multiplied by a factor of 1.5. The weight of test-fuel charges for fireplace-grate usable-firebox-area tests, shall not exceed the weight of test-fuel charges determined for the entire fireplace floor area.

**ZERO DRIFT** is the difference in the analyzer reading from the initial calibration response at the zero concentration level after a stated period of operation during which no unscheduled maintenance, repair, or adjustment took place.

## SECTION 31.202 — TESTING

**31.202.1 Applicability.** This method is applicable for the certification and auditing of fireplace particulate emission factors. This method describes the test facility, fireplace installation requirements, test-fuel charges, and fireplace operation as well as procedures for determining burn rates and particulate emission factors.

**31.202.2 Principle.** Particulate matter emissions are measured from a fireplace burning prepared test-fuel charges in a test facility maintained at a set of prescribed conditions.

### 31.202.3 Test Apparatus.

**31.202.3.1 Fireplace Temperature Monitors.** Devices capable of measuring flue-gas temperature to within 1.5 percent of expected absolute temperatures.

**31.202.3.2 Test Facility Temperature Monitor.** A thermocouple located centrally in a vertically oriented pipe shield 6 inches (150 mm) long, 2 inches (50 mm) diameter that is open at both ends, capable of measuring air temperature to within 1.5 percent of expected absolute temperatures.

**31.202.3.3 Balance.** Balance capable of weighing the test-fuel charge(s) to within 0.1 lb (0.05 kg).

**31.202.3.4 Moisture Meter.** Calibrated electrical resistance meter for measuring test-fuel moisture to within 1 percent moisture content (dry basis).

**31.202.3.5 Anemometer.** Device capable of detecting air velocities less than 20 ft/min (0.10 m/sec), for measuring air velocities near the fireplace being tested.

**31.202.3.6 Barometer.** Mercury, aneroid or other barometer capable of measuring atmospheric pressure to within 0.1 inch Hg (2.5 mm Hg).

**31.202.3.7 Draft Gauge.** Electromanometer or other device for the determination of flue draft (i.e., static pressure) readable to within 0.002 inches of water column (0.50 Pa).

**31.202.3.8 Combustion Gas Analyzer.** Combustion gas analyzers for measuring Carbon Dioxide (CO<sub>2</sub>), Carbon Monoxide (CO), and Oxygen (O<sub>2</sub>) in the fireplace exhaust-gas stream must meet all of the following measurement system performance specifications:

1. **Analyzer Calibration Error.** Shall be less than  $\pm 2$  percent of the span value for the zero, mid-range, and high-range calibration gases.

2. **Sampling System Bias.** Shall be less than  $\pm 5$  percent of the span value for the zero, mid-range, and high-range calibration gases.

3. **Zero Drift.** Shall be less than  $\pm 3$  percent of the span over the period of each run.

4. **Calibration Drift.** Shall be less than  $\pm 3$  percent of the span value over the period of each run.

5. **Response Time.** Shall be less than 1.5 minutes.

**31.202.4 Emissions Sampling Method.** Use the emission sampler system (ESS) as described in Section 31.203.12 or an equivalent method as determined by the application of the U. S. EPA Method 301 Validation Procedure (Federal Register, December 12, 1992, Volume 57, Number 250, page 11998) and upon approval of DOE.

**31.202.5 Fireplace Installation and Test Facility Requirements.** The fireplace being tested must be constructed, if site-built, or installed, if manufactured, in accordance with the designer's / manufacturer's written instructions. The chimney shall have a total vertical height above the base of the fire chamber of not less than 15 feet (4 600 mm). The fireplace chimney exit to the atmosphere must be freely communicating with the fireplace combustion makeup-air source. There shall be no artificial atmospheric pressure differential imposed between the chimney exit to the atmosphere and the fireplace makeup-air inlet.

**31.202.6 Fireplace Aging and Curing.** A fireplace of any type shall be aged before certification testing begins. The aging procedure shall be conducted and documented by the testing laboratory.

**31.202.6.1 Catalyst-Equipped Fireplaces.** Operate the catalyst-equipped fireplace using fuel described in Section 31.203. Operate the fireplace with a new catalytic combustor in place and in operation for at least 50 hours. Record and report hourly catalyst exit temperatures, the hours of operation, and the weight of all fuel used.

**31.202.6.2 Non-Catalyst-Equipped Fireplaces.** Operate the fireplace using the fuel described in Section 31.203 for at least 10 hours. Record and report the hours of operation and weight of all fuel used.

**31.202.7 Pretest Preparation.** Record the test-fuel charge dimensions, moisture content, weights, and fireplace (and catalyst if equipped) descriptions.

The fireplace description shall include photographs showing all externally observable features and drawings showing all internal and external dimensions needed for fabrication and/or construction. The drawings must be verified as representing the fireplace being tested and signed by an authorized representative of the testing laboratory.

**31.202.8 Test Facility Conditions.** Locate the test facility temperature monitor on the horizontal plane that includes the primary air intake opening for the fireplace. Locate the temperature monitor 3 to 6 feet (1 000 to 2 000 mm) from the front of the fireplace in the 90° sector in front of the fireplace. Test facility temperatures shall be maintained between 65° and 90°F (18° and 32°C). Use an anemometer to measure the air velocity. Measure and record the room-air velocity within 2 feet (600 mm) of the test fireplace before test initiation and once immediately following the test-burn completion. Air velocity shall be less than 50 feet/minute (250 mm/second) without the fireplace operating.

## SECTION 31.203 — TEST PROTOCOL

**31.203.1 Test Fuel.** Fuel shall be air dried Douglas fir dimensional lumber or cordwood without naturally associated bark. Fuel pieces shall not be less than 1/2 nor more than 5/6 of the length of the average fire chamber width. Fuel shall be split or cut into pieces with no cross-sectional dimension greater than 6 inches (152 mm). Spacers, if used, shall not exceed 3/4 inches (19 mm) in thickness and 15 percent of the test-fuel charge weight. Fuel moisture shall be in the range of 16 to 20 percent (wet basis) or 19 to 25 percent (dry basis) meter reading.

**31.203.2 Test-Fuel Loading Density.** The wet (with moisture) minimum weight of each test-fuel charge shall be calculated by multiplying the hearth area in square feet by 7.0 pounds per square foot (square meters x 0.30 kg/m<sup>2</sup>) ( $\pm 10$  percent). Three test-fuel charges shall be prepared for each test-burn.

**31.203.3 Kindling.** The initial test-fuel charge of the three test-fuel charge test-burn shall be started by using a kindling-fuel charge which is up to 50 percent of the first test-fuel charge weight. Kindling-fuel pieces can be any size needed to start the fire or whatever is recommended in the manufacturer's (builder's) instructions to consumers. The kindling-fuel charge weight is not part of the initial test-fuel charge weight but is in addition to it.

(Insert as Page 574c)

**31.203.4 Test-Burn Ignition.** The fire can be started with or without paper. If used, the weight of the paper must be included in test-fuel charge weight. The remainder of the test-fuel charge may be added at any time after kindling ignition except that the entire first test-fuel charge must be added within 10 minutes after the start of the test (i.e., the time at which the flue-gas temperature at the 8-foot (2 440 mm) level is over 25°F (14°C) greater than the ambient temperature of the test facility).

**31.203.5 Test Initiation.** Emissions and flue-gas sampling are initiated immediately after the kindling has been ignited and when flue-gas temperatures in the center of the flue at an elevation of 8 feet (2 440 mm) above the base (floor) of the fire chamber reach 25°F (14°C) greater than the ambient temperature of the test facility.

**31.203.6 Sampling Parameters.** Sampling (from the 8-foot [2 440 mm] flue-gas temperature measurement location) must include:

1. Particulate Emissions
2. Carbon Dioxide (CO<sub>2</sub>)<sup>1</sup>
3. Carbon Monoxide (CO)<sup>1</sup>
4. Oxygen (O<sub>2</sub>)<sup>1</sup>
5. Temperature(s)

<sup>1</sup> These gases shall be measured on-line (real-time) and recorded at a frequency of not less than once every 5 minutes. These 5-minute readings are to be arithmetically averaged over the test-burn series or alternatively, a gas bag sample can be taken at a constant sample rate over the entire test-burn series and analyzed for the required gases within one hour of the end of the test-burn.

If a fireplace is equipped with an emissions control device which is located downstream from the 8-foot (2 440 mm) flue-gas temperature measurement location, a second temperature, particulate, and gaseous emissions sampling location must be located downstream from the emissions control device but not less than 4 flue diameters upstream from the flue exit to the atmosphere. The two sampling locations must be sampled simultaneously during testing for each fireplace configuration being tested.

**31.203.7 Test-Fuel Additions and Test Completion.** The second and third test-fuel charges for a test-burn may be placed and burned in the fire chamber at any time deemed reasonable by the operator or when recommended by the manufacturer's and/or builder's instructions to consumers.

No additional kindling may be added after the start of a test-burn series and the flue-gas temperature at the 8-foot (2 440 mm) level above the base of the hearth must always be 25°F (14°C) greater than the ambient temperature of

the test facility for a valid test-burn series. Each entire test-fuel charge must be added within 10 minutes from the addition of the first piece.

A test (i.e., a three test-fuel charge test-burn series) is completed and all sampling and measurements are stopped when all three test-fuel charges have been consumed (to more than 90 percent by weight) in the firebox and the 8-foot (2 440 mm) level flue-gas temperature drops below 25°F (14°C) greater than the ambient temperature of the test facility. Within 5 minutes after the test-burn is completed and all measurements and sampling has stopped, the remaining coals and/or unburned fuel, shall be extinguished with a carbon dioxide fire extinguisher. All of the remaining coals, unburned fuel, and ash shall be removed from the firebox and weighed to the nearest 0.1 pound (0.05 kg). The weight of these unburned materials and ash shall be subtracted from the total test-burn fuel weight when calculating the test-burn burn rate. A test-burn is invalid if less than 90 percent of the weight of the total test-fuel charges plus the kindling weight have been consumed in the fireplace firebox.

**31.203.8 Test-Fuel Charge (Load) Adjustments.** Test-fuel charges may be adjusted (i.e., repositioned) once during the burning of each test-fuel charge. The time used to make this adjustment shall be less than 15 seconds.

**31.203.9 Air Supply Adjustment.** Air supply controls, if the fireplace is equipped with controls, may not be adjusted during any test-burn series after the first 10 minutes of startup of each fuel load. All air supply settings must be set to the lowest level at the start of a test and shall remain at the lowest setting throughout a test-burn.

**31.203.10 Auxiliary Fireplace Equipment Operation.** Heat exchange blowers (standard or optional) sold with the fireplace shall be operated during all test-burns following the manufacturer's written instructions. If no manufacturer's written instructions are available, operate the heat exchange blower in the "high" position. (Automatically operated blowers shall be operated as designed.) Shaker grates, bypass controls, afterburners, or other auxiliary equipment may be adjusted only once per test-fuel charge following the manufacturer's written instructions. Record and report all adjustments on a fireplace operational written-record.

**31.203.11 Fireplace Configurations.** One, 3 test-fuel charge test-burn shall be conducted for each of the following fireplace operating configurations:

1. Door(s) closed, with hearth grate;
2. Door(s) open, with hearth grate;
3. Door(s) closed, without hearth grate;
4. Door(s) open, without hearth grate; and
5. With no door(s), and draft inducer on.

No test-burn series is necessary for any configuration the appliance design cannot or is not intended to accommodate. If a configuration is not tested, the reason must be submitted with the test report and the appliance label must state that the appliance cannot be used in that configuration by consumer users.

One emission factor result, or one emission factor average, as provided in paragraph 31.203.11.2, from each fireplace configuration tested shall be compiled into an arithmetic average of all the configurations tested for determining compliance with the requirements of paragraph 31.204.2.

**31.203.11.1 Closed-Door(s) Testing.** For all closed-door test configurations, the door(s) must be closed within 10 minutes from the addition of the first test-fuel piece of each test-fuel charge in a test-burn. During a test-burn, the door(s) cannot be re-opened except during test-fuel reload and adjustment as referenced in Sections 31.203.7 and 31.203.8.

**31.203.11.2 Additional Test-Burn.** The testing laboratory may conduct more than one test-burn series for each of the applicable configurations specified in Section 31.203.11. If more than one test-burn is conducted for a specified configuration, the results from at least 2/3 of the test-burns for that configuration shall be used in calculating the arithmetic average emission factor for that configuration. The measurement data and results of all tests conducted shall be reported regardless of which values are used in calculating the average emission factor for that configuration.

**31.203.12 Emissions Sampling System (ESS).**

**31.203.12.1 Principle.** Figure 31-2-1 shows a schematic of an ESS for sampling solid-fuel-fired fireplace emissions. Except as specified in Section 31.202.4, an ESS in this configuration shall be used to sample all fireplace emissions. The ESS shall draw flue gases through a 15 inch (380 mm) long, 3/8 inch (10 mm) O.D. stainless steel probe which samples from the center of the flue at an elevation which is 8 feet (2 440 mm) above the floor of the firebox (i.e., the hearth). A flue-gas sample shall then travel through a 3/8 inch (10 mm) O.D. Teflon® tube, and a heated U. S. EPA Method 5-type glass-fiber filter (40 CFR Part 60, Appendix A) for collection of particulate matter. The filter shall be followed by an in-line flow-through cartridge containing 20 grams of XAD-2 sorbent resin for collecting semi-volatile hydrocarbons. Water vapor shall then be removed from the sampled gas by a silica-gel trap. Flue-gas oxygen concentrations, which shall be used to determine the ratio of flue-gas volume to the amount of fuel burned, are measured within the ESS system by an electrochemical cell meeting the performance specifications presented in Section 31.202.3.8 (1).

The ESS shall use a critical orifice to maintain a nominal flue-gas sampling rate of 0.035 cfm (0.0167 liters per second). The actual flow rate through each critical orifice shall be determined to within 0.000354 cubic feet (0.01 liters) per second before and after each test-burn with a bubble flow meter to document exact sampling rates. The post-test-burn critical-orifice flow-rate determinations shall be performed before the ESS is dismantled for sample recovery and clean-up. Pre-test-burn and post-test-burn critical-orifice flow-rate measurements shall be within 0.0000117 cubic feet (0.00033 liters) per second of each other or the test-burn emissions results shall be invalid. Temperatures shall be monitored using type K ground-isolated, stainless-steel-sheathed thermocouples.

The ESS unit shall return particle-free and dry exhaust gas to the flue via a 1/4 inch (6 mm) Teflon® line and a 15 inch (380 mm) stainless steel probe inserted into the flue. A subsample aliquot of the flue-gas sample-gas stream exiting the ESS unit, shall be pumped into a 1 cubic foot (29 liter) Tedlar® bag for measuring the average carbon dioxide, carbon monoxide, and confirmation of average oxygen concentrations for the test period. Flow to the subsample gas bag shall be controlled by a solenoid valve connected to the main pump circuit and a fine-adjust needle-controlled flow valve. The solenoid valve shall be open only when the pump is activated, allowing the subsample gas to be pumped into the gas bag at all times when the ESS pump is on. The rate of flow into the bag shall be controlled by the fine-adjust metering needle-valve which is adjusted at setup so that 4.7 to 5.2 gal (18 to 20 liters) of gas is collected over the entire 3 test-fuel charge test-burn without over-pressurizing the gas sample bag.

**31.203.12.2 The Data Acquisition and Control System.** The data acquisition and control system for the ESS is shown in Figure 31-2-2. This system consists of a personal computer (PC) containing an analog-to-digital data processing board (12-bit precision), a terminal (connection) box, and specialized data acquisition and system control software (called CONLOG).

For fireplace testing, the CONLOG software is configured to control, collect, and store the following data:

1. Test-period starting and ending times and dates, and total length of sampling period,
2. Pump-cycle on/off, cycle length and thermocouple (TC) cycle recording interval (frequency),
3. Temperature records, including flue-gas and ambient temperatures, averaged over pre-selected intervals,
4. Date, times, and weights of each added fuel load, and

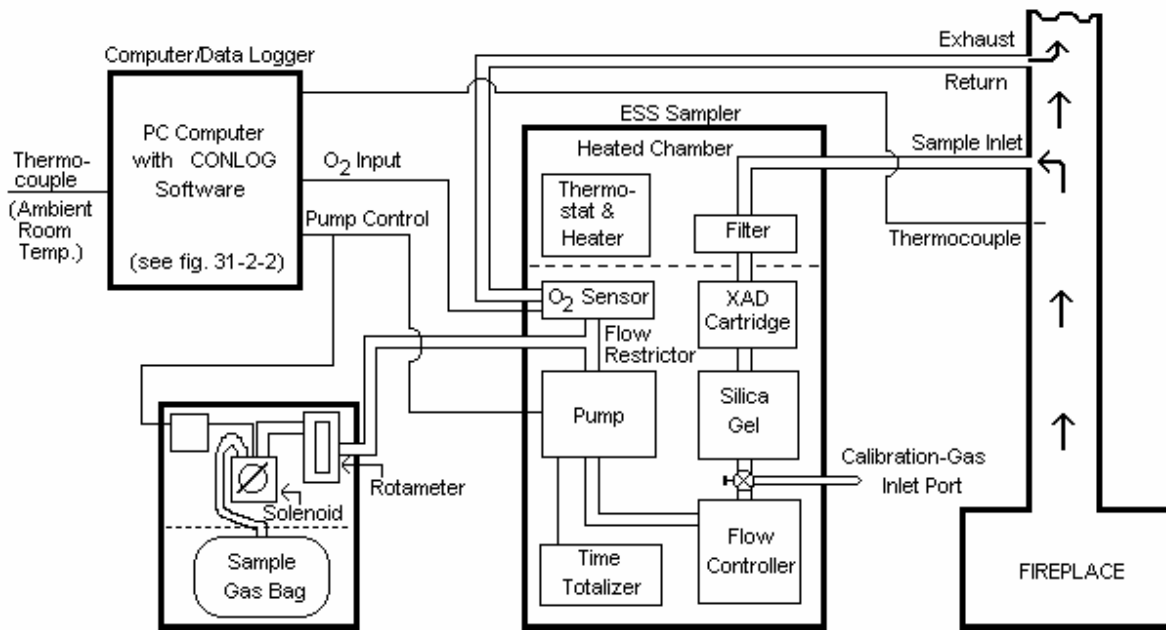

Figure 31-2-1. Schematic of ESS/Data Logger system.

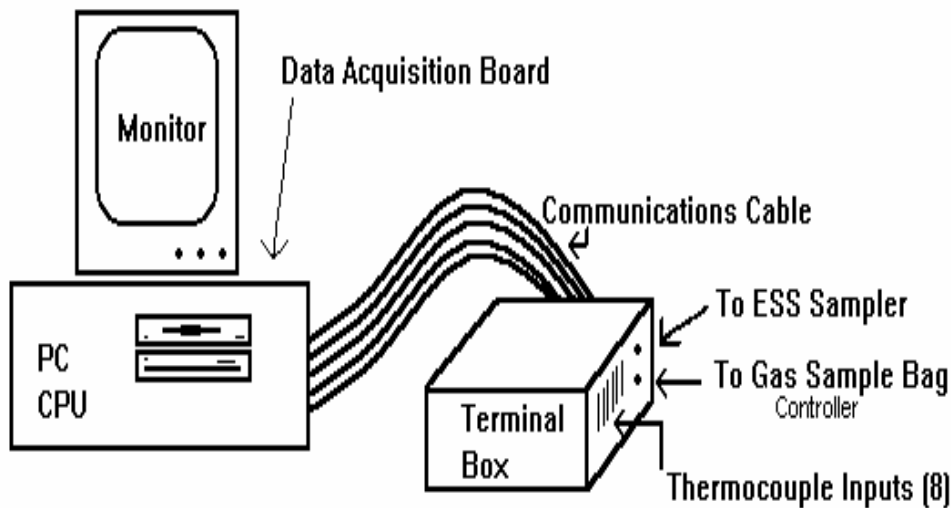

Figure 31-2-2. ESS data logger system.

(Insert as Page 574f)

5. Flue-gas oxygen measurements taken during each sample cycle.

During testing, instantaneous readings of real-time data shall be displayed on the system status screen. These data shall include the date, time, temperatures for each of the TCs, and flue-gas oxygen concentrations. The most recent 15 sets of recorded data shall also be displayed.

Flue-gas sampling and the recording of flue-gas oxygen concentrations shall only occur when flue-gas temperatures are above 25°F (14°C) greater than the ambient temperature of the test facility. Temperatures and fueling shall always be recorded at five-minute intervals regardless of flue-gas temperature. The ESS sampling-pump operating cycle shall be adjustable as described in Section 31.203.12.3.

**31.203.12.3 ESS Sampling-Pump Operating Cycle.** The ESS sampling-pump operating cycle shall be adjusted to accommodate variable test-fuel charge sizes, emission factors, and the length of time needed to complete a test-burn series. The sampler-pump operation shall be adjustable from 1 second to 5 minutes (100 percent) "on" for every 5-minute test-burn data-recording interval. This will allow adjustment for the amount of anticipated emissions materials that will be sampled and deposited on the ESS filter, XAD-2, and the other system components. It is recommended that the minimum sample quantities stipulated in Section 31.203.12.4 be used to calculate the appropriate pump cycle "on" and "off" periods. It should be noted that if the sampler collects too much particulate material on the filter and in the XAD-2 cartridge, the unit may fail the sample flow calibration check required at the end of each test-burn.

**31.203.12.4 Minimum Sample Quantities.** For each complete 3 test-fuel charge test-burn, the ESS must catch a minimum total particulate material mass of at least 0.231 grains (15 mg). Alternatively, the ESS must sample a minimum of 10 cubic feet (283 liters) during each 3 test-fuel charge test-burn. If this volume cannot be sampled in the test-burn time period, two ESS samplers must be utilized to sample fireplace emissions simultaneously during each test-burn. If emissions results from the two ESSs are different by more than 10 percent of the lower emissions-factor result, the test-burn results are invalid. An arithmetic average is calculated for test-burn results when two ESSs are utilized.

**31.203.12.5 Equipment Preparation and Sample Processing Procedures.**

**31.203.12.5.1.** Prior to emissions testing, the ESS unit shall be prepared with a new, tared glass-fiber filter and a clean XAD-2 sorbent-resin cartridge. Within 3 hours after testing is completed, the stainless steel sampling probe,

Teflon® sampling line, filter holder, and XAD-2 cartridge(s) shall be removed from the test site and transported to the laboratory for processing. Each component of the ESS sampler shall be processed as follows:

1. Filter: The glass fiber filter (4 inches (102 mm) in diameter) shall be removed from the ESS filter housing and placed in a petri dish for desiccation and gravimetric analysis.

2. XAD-2 sorbent-resin cartridge: The sorbent-resin cartridge shall be extracted in a Soxhlet extractor with dichloromethane for 24 hours. The extraction solution shall be transferred to a tared glass beaker and evaporated in an ambient-air dryer. The beaker with dried residue shall then be desiccated to constant weight (less than  $\pm 0.5$  mg change within a 2-hour period), and the extractable residue shall be weighed.

3. ESS hardware: All hardware components which are in the flue-gas sample stream (stainless steel probe, Teflon® sampling line, stainless steel filter housing, and all other Teflon® and stainless steel fittings) through the top of the sorbent-resin cartridge, shall be cleaned with a solvent mixture of 50 percent dichloromethane and 50 percent methanol. The cleaning solvent solutions shall be placed in tared glass beakers, evaporated in an ambient-air dryer, desiccated to constant weight (less than  $\pm 0.5$  mg change within a 2-hour period), and weighed.

EPA Method 5H procedures (40 CFR Part 60, Appendix A) for desiccation and weighing time intervals shall be followed for steps 1 through 3 above.

**31.203.12.5.2** The ESS shall be serviced both at the start and end of a fireplace testing period. During installation, leak checks shall be performed; the thermocouples, fuel-weighing scale, and oxygen-cell shall be calibrated, and the data logger shall be programmed. At the end of the test period, final calibration, and leak-check procedures shall again be performed, and the ESS sampling line, filter housing, XAD-2 cartridge, sampling probe, and Tedlar® bag shall be removed, sealed, and transported to the laboratory for analysis. If the pre-test and post-test leak checks of the ESS system exceed 0.00033 liters per second, the test-burn emission results shall be invalid.

**31.203.12.6 Data Processing and Quality Assurance.**

**31.203.12.6.1** Upon returning to the laboratory facilities, the data file (computer disk) shall be reviewed to check for proper equipment operation. The data-logger data files, log books, and records maintained by field staff shall be reviewed to ensure sample integrity.

The computer-logged data file shall be used in conjunction with the ESS particulate samples and sample-

(Insert as Page 574g)

gas bag analyses to calculate the emission factor, emission rate, and fireplace operational parameters. An example ESS results report is presented in Table 31-2-A.

**31.203.12.6.2 Burning Period.** The total burning period is calculated by:

$$\text{Total Burning Period} = (\text{Length of each sample cycle}) \times (\text{Number of flue temperature readings over } 25^{\circ}\text{F (} 14^{\circ}\text{C) greater than the ambient temperature of the test facility}).$$

**WHERE:**

1. Length of each sample cycle: The time between each temperature recording as configured in the CONLOG software settings (standardized at 5 minutes).
2. Number of flue temperature readings during fireplace use: The total number of temperature readings when the calibrated temperature value was more than 25°F (14°C) greater than the ambient temperature of the test facility.

**31.203.12.6.3 Particulate Emissions.**

**31.203.12.6.3.1 ESS Particulate Emission Factor.** The equation for the total ESS particulate emission factor for each test-burn presented below produces reporting units of grams per dry kilogram of fuel burned (g/kg):

$$\text{Particulate emission factor (g/kg)} = \frac{(\text{Particulate Catch}) \times (\text{Stoichiometric Volume}) \times (\text{Flue-gas Dilution Factor})}{(\text{Sampling Time}) \times (\text{Sampling Rate})}$$

**WHERE:**

1. Particulate Catch: The total mass, in grams, of particulate material caught on the filter, in the XAD-2 resin cartridge (semi-volatile compounds); and in the probe clean-up and rinse solutions.
2. Stoichiometric Volume: Stoichiometric volume is the volume of dry air needed to completely combust one dry kilogram of fuel with no "excess air". This value is determined by using a chemical reaction balance between the specific fuel being used and the chemical components of air. The stoichiometric volume for Douglas fir is 86.78 cubic feet per pound (5 404 liters per dry kilogram) at 68°F (20°C) and 29.92 inches (760 mm) of mercury pressure.
3. Flue-gas Dilution Factor: The degree to which the sampled combustion gases have been diluted in the flue by air in excess of the stoichiometric volume (called excess air). The dilution factor is obtained by using the average sampled carbon dioxide and carbon monoxide values obtained from the sample gas bag analyses and the following equation:

$$\text{Flue-Gas Dilution Factor} = \frac{18.53 + \left( \frac{e_1 - e_2}{18.53} \times \frac{\text{CO}_2 + \frac{1}{2} \text{CO}}{\text{CO}_2 + \frac{1}{2} \text{CO}} \times 2.37 \right)}{\text{CO}_2 + \frac{1}{2} \text{CO}}$$

Note: Multiplying the g/kg emission factor by the burn rate (dry kg/hr) yields particulate emissions in grams per hour (g/hr). Burn rate is calculated by the following equation:

$$\text{Burn Rate (kg/hr)} = \frac{\text{Total Fuel (kg)}}{\text{Total Burn Period (hours)}}$$

**WHERE:**

Total Fuel is the total fuel added during the entire test-burn minus the remaining unburned materials at the end of the test burn.

**4. Sampling Time: The number of minutes the sampler pump operated during the total test-burn period.**

5. Sampling Rate: Sampling rate is controlled by the critical orifice installed in the sampler. The actual calibrated sampling rate is used here.

**31.203.12.6.3.2 EPA Method 5H Particulate Emissions.**

ESS-measured emissions factors submitted to DOE for approval must first be converted to U. S. EPA Method 5H equivalents. The ESS particulate emissions factor results obtained in Section 31.203.12.6.1 are converted to be equivalent to the U. S. EPA Method 5H emissions factor results by the following equation:

$$1.254 + (0.302 \times \text{PEF}) + (1.261 \times 10^{-6} \times \text{PEF}^2)$$

**WHERE:**

PEF is the ESS-measured particulate emission factor for a test burn.

**31.203.12.6.4 CO Emissions.** The carbon monoxide (CO) emission factor equation produces grams of CO per dry kilogram of fuel burned. The grams per kilogram equation includes some equation components described above.

CO emission factor (g/kg) =

$$\frac{(\text{Fraction CO}) \times (\text{Stoich. Volume}) \times (\text{Dilution Factor}) \times (\text{Molecular Weight of CO})}{(24.45 \text{ L/mole})}$$

**WHERE:**

1. Fraction CO: The fraction of CO measured in the gas sampling bag.

**Note:** Percent CO divided by 100 gives the fraction CO.

2. Molecular Weight of CO: The gram molecular weight of CO, 28 pounds per pound-mole (28.0 g/g-mole).

Multiplying the results of the above equation by the burn rate (dry kg/hr) yields the grams per hour (g/hr) CO emission rate.

**Table 31-2-A Example ESS Data Results Format**

**ESS Emission Results**

Test Facility Location: xxxx  
 Test Laboratory: xxxx  
 Test-Burn Number: xxxx  
 Start Time/Date: xxxx  
 End Time/Date: xxxx  
 Fireplace Model: xxxx

**TIME**

Total Test Period 152.3 hours  
 Total Burn Time 64.6 hours  
 Flue >25 Degrees F above ambient temperature 42.4 %

**CARBON MONOXIDE EMISSIONS**

Gram / Kilogram 48.0 g/kg  
 Gram / Hour 64.0 g/hr  
 Gram / Cubic Meter 1.25 g/m<sup>3</sup>

**ESS SETTINGS**

ESS Sample Rate 1.004 l/min  
 Sample Cycle 5.0 min  
 Sample Time / Sample Cycle 0.443 min

**AVERAGE TEMPERATURES**

Fuel-Gas Temperatures 275 °F  
 135 °C  
 Flue Exit Temperature 308 °F  
 154 °C  
 Test Facility Ambient Temperature 66 °F  
 19 °C

**TEST FUEL**

Total Fuel Used (wet weight) 101.3 kg  
 Ave. Fuel Moisture (dry basis) 17.7 %  
 Total Fuel Used (dry weight) 86.1 kg  
 Average Test-Fuel Charge 14.5 kg  
 Average Burn Rate 1.33 dry kg/hr

**AVERAGE FLUE-GAS CONCENTRATIONS**

Flue Oxygen (SE) 18.15 %  
 Flue Oxygen (gas bag or analyzer) 18.05 %  
 Flue CO (gas bag or analyzer) 0.10 %  
 Flue CO<sub>2</sub> (gas bag or analyzer) 2.60 %

**PARTICULATE EMISSIONS (EPA Method 5H Equivalent)**

Gram / Kilogram 2.6 g/kg  
 Gram / Hour 3.4 g/hr  
 Gram / Cubic Meter 0.06 g/m<sup>3</sup>

**BREAKDOWN OF ESS PARTICULATE SAMPLE**

Rinse 25.5 mg  
 XAD 6.3 mg  
 Filter 15.7 mg  
 Blank 0.0 mg  
**TOTAL 47.4 mg**

Notes:

NM = Not Measured, NA = Not Applicable, NU = Not Used  
 Total time flue temperature greater than 25°F over ambient temperature.

TEST PERFORMED BY: XYZ Testing International, Olympia Washington, 98504

**31.203.13 Calibrations.**

**31.203.13.1 Balance.** Before each certification test, the balance used for weighing test-fuel charges shall be audited by weighing at least one calibration weight (Class F) that corresponds to 20 percent to 80 percent of the expected test-fuel charge weight. If the scale cannot reproduce the value of the calibration weight within 0.1 lb (0.05 kg) or 1 percent of the expected test-fuel charge weight, whichever is greater, re-calibrate the scale before use with at least five calibration weights spanning the operational range of the scale.

**31.203.13.2 Temperature Monitor.** Calibrate the Temperature Monitor before the first certification test and semiannually thereafter.

**31.203.13.3 Fuel Moisture Meter.** Calibrate the Fuel Moisture Meter as per the manufacturer's instructions before each certification test.

**31.203.13.4 Anemometer.** Calibrate the anemometer as specified by the manufacturer's instructions before the first certification test and semiannually thereafter.

**31.203.13.5 Barometer.** Calibrate the Barometer against a mercury barometer before the first certification test and semiannually thereafter.

**31.203.13.6 Draft Gauge.** Calibrate the Draft Gauge as per the manufacturer's instructions; a liquid manometer does not require calibration.

**31.203.13.7 ESS.** The ESS shall be calibrated as specified in Section 31.203.12.1.

**31.203.14 Reporting Criteria.** Submit both raw and reduced data for all fireplace tests. Specific reporting requirements are as follows:

**31.203.14.1 Fireplace Identification.** Report fireplace identification information including manufacturer, model, and serial number. Include a copy of fireplace installation and operation manuals.

**31.203.14.2 Test Facility Information.** Report test facility location, temperature, and air velocity information.

**31.203.14.3 Test Equipment Calibration and Audit Information.** Report calibration and audit results for the test-fuel balance, test-fuel moisture meter, analytical balance, and sampling equipment including volume metering systems and gaseous analyzers.

**31.203.14.4 Pretest Information and Conditions.** Report all pretest conditions including test-fuel charge weight, fireplace temperatures, and air supply settings.

**31.203.14.5 Particulate Emission Data.** Report a summary of test results for all test-burns conducted and the arithmetically averaged emission factor for all test-burns used for certification. Submit copies of all data sheets and other records collected during the testing. Submit examples of all calculations.

**31.203.14.6 Required Test Report Information and Suggested Format.** Test report information requirements to be provided to DOE for approval/certification of fireplaces are presented in this Standard. The requirements are presented here in a recommended report format.

**31.203.14.6.1 Introduction.**

1. Purpose of test: certification or audit.
2. Fireplace identification: manufacturer, model number, catalytic/non-catalytic, and options. Include a copy of fireplace installation and operation manuals.
3. Laboratory: name, location, and participants.
4. Test information: date fireplace was received, date of tests, sampling methods used, and number of test-burns.

**31.203.14.6.2 Summary and Discussion of Results.**

1. Table of results: test-burn number, burn rate, particulate emission factor (in U. S. EPA Method 5H equivalents), efficiency (if determined), and averages (indicate which test-burns are used).
2. Summary of other data: test facility conditions, surface temperature averages, catalyst temperature averages, test-fuel charge weights, and test-burn times.
3. Discussion: specific test-burn problems and solutions.

**31.203.14.6.3 Process Description.**

1. Fireplace dimensions: volume, height, width, lengths (or other linear dimensions), weight, and hearth area.
2. Firebox configuration: air supply locations and operation, air supply introduction location, refractory location and dimensions, catalyst location, baffle and by-pass location and operation (include line drawings and photographs).
3. Process operation during test: air supply settings and adjustments, fuel bed adjustments, and draft.
4. Test fuel: test fuel properties (moisture and temperature), test fuel description (include line drawing or photograph), and test fuel charge density.

**31.203.14.6.4 Sampling Locations.** Describe sampling location relative to fireplace. Include line drawings and photographs.

**31.203.14.6.5 Sampling and Analytical Procedures.**

1. Sampling methods: brief reference to operational and sampling procedures, and optional and alternative procedures used.
2. Analytical methods: brief description of sample recovery and analysis procedures.

(Insert as Page 574j)

### **31.203.14.6.6 Quality Control and Assurance Procedures and Results.**

1. Calibration procedures and results: Certification, sampling, and analysis procedures.
2. Test method quality control procedures: leak-checks, volume-meter checks, stratification (velocity) checks, and proportionality results.

### **31.203.14.6.7 Appendices.**

1. Results and Example Calculations. Include complete summary tables and accompanying examples of all calculations.
2. Raw Data. Include copies of all uncorrected data sheets for sampling measurements, temperature records, and sample recovery data. Include copies of all burn rate and fireplace temperature data.
3. Sampling and Analytical Procedures. Include detailed description of procedures followed by laboratory personnel in conducting the certification test, emphasizing particularly, parts of the procedures differing from the prescribed methods (e.g., DOE approved alternatives).
4. Calibration Results. Summary of all calibrations, checks, and audits pertinent to certification test results including dates.
5. Participants. Test personnel, manufacturer representatives, and regulatory observers.
6. Sampling and Operation Records. Copies of uncorrected records of activities not included on raw data sheets (e.g., fireplace door open times and durations).
7. Additional Information. Fireplace manufacturer's written instructions for operation during the certification test and copies of the production-ready (print-ready) temporary and permanent labels required in Section 31.208 shall be included in the test report prepared by the test laboratory.

### **31.203.14.7 References.**

1. Code of Federal Regulations, U. S. EPA Title 40, Part 60, Subpart AAA and Appendix A (40 CFR Part 60).
2. Barnett, S. G. and P. G. Fields, 1991, In-Home Performance of Exempt Pellet Stoves in Medford, Oregon, prepared for U. S. Department of Energy, Oregon Department of Energy, Tennessee Valley Authority, and Oregon Department of Environmental Quality, July 1991.
3. Barnett, S. G. and R. R. Roholt, 1990, In-Home Performance of Certified Pellet Stoves in Medford and Klamath Falls, Oregon, prepared for the U. S. Department of Energy, 1990.
4. Barnett, S. G., 1990, "Field Performance of Advanced Technology Woodstoves in Glens Falls, New York, 1988-1989", for New York State Energy Research

and Development Authority, U. S. EPA, Coalition of Northeastern Governors, Canadian Combustion Research Laboratory, and the Wood Heating Alliance, December 1989.

### **SECTION 31.204 — APPROVAL PROCEDURE FOR FIREPLACES.**

On or after the effective date of this regulation, a manufacturer or builder of a fireplace who wishes to have a fireplace model line or fireplace design designated as an approved (or certified) fireplace, shall submit to DOE for its review the following information:

**31.204.1** Manufacturer name and street address, model or design identification, construction specifications, and drawings of the firebox and required chimney system.

**31.204.2** A test report prepared in accordance with Section 31.203.14.6 showing that testing has been conducted by a DOE approved and U. S. EPA accredited laboratory, and that the arithmetically averaged particulate emission factors for that fireplace model line or design, tested in accordance with UBC Standard Section 31.202, does not exceed 7.3 g/kg (U. S. EPA Method 5H equivalent as determined in Section 31.203.12.6.3.2) for factory-built fireplace model lines or designs or 12.0 g/kg (U. S. EPA Method 5H equivalent as determined in Section 31.203.12.6.3.2) for new certified masonry fireplace model lines or designs. After January 1, 1999, particulate emission factors for factory-built and new certified masonry fireplace model lines or designs shall not exceed 7.3 g/kg (U. S. EPA Method 5H equivalents as determined in Section 31.203.12.6.3.2).

### **SECTION 31.205 — APPROVAL OF NON-TESTED FIREPLACES.**

On or after the effective date of this regulation, DOE may grant approval for a fireplace model line or design that has not been tested pursuant to Section 31.204 upon submission of the following by the applicant:

**31.205.1** Manufacturer name and street address, model or design identification, construction specifications, and drawings of the internal assembly system.

**31.205.2** Documentation from an EPA accredited laboratory that the model is a fireplace within the definition of this regulation, has substantially the same core construction as a model already tested by a DOE approved and EPA accredited laboratory, and is substantially similar to the approved model in internal assembly design, combustion function, and probable emissions performance as listed in Section 31.204.2.

(Insert as Page 574k)

**SECTION 31.206 — APPROVAL THROUGH ALTERNATIVE TEST PROTOCOL.**

As provided in Section 31.202.4, an alternative testing protocol may be submitted by a DOE approved and EPA accredited laboratory for acceptance by DOE as equivalent to UBC Standard 31-2.

**SECTION 31.207 — APPROVAL TERMINATION.**

All fireplace model line or design approvals shall terminate five years from the approval date. Previously approved fireplace model line and/or design may be granted re-approval (re-certification) upon application to and review by DOE. No testing shall be required for fireplace model line or design re-approvals unless DOE determines that design changes have been incorporated into the fireplace that could adversely affect the emissions factor, or testing is otherwise stipulated by DOE.

DOE may revoke a fireplace model line or design approval certification if it is determined that the fireplaces being produced in a specific model line do not comply with the requirements of Section 31.200. Such a determination shall be based on all available evidence, including:

1. Test data from a retesting (audit test) of the original unit on which the certification test was conducted or a sample unit from the current model line;
2. A finding that the certification test was not valid;
3. A finding that the labeling of the fireplace does not comply with the requirements of Section 31.200;
4. Failure by the fireplace manufacturer (builder) to comply with reporting and record keeping requirements under Section 31.200;
5. Physical examination showing that a significant percentage of production units inspected are not similar in all material respects to the fireplace submitted for testing; or
6. Failure of the manufacturer to conduct a quality assurance program in conformity with Section 31.208.

Revocation of certification under this section shall not take effect until the manufacturer (builder) concerned has been given written notice by DOE setting forth the basis for the proposed determination and an opportunity to request a hearing.

**SECTION 31.208 — QUALITY CONTROL.**

Once within 30 days of each annual anniversary after the initial approval/certification, a DOE approved and U. S. EPA accredited laboratory shall inspect the most recently produced fireplace of an approved model line or design at its manufacturing location (site, if site-built) to document adherence to the approved/certified fireplace design specifications. If no fireplaces of an approved mode line or design were produced (built) during the previous 12 months, no inspection is required.

**(Insert as Page 574I)**

An inspection report for each approved fireplace model line or design must be submitted to DOE within 30 days after the inspection date. The inspection report shall include, as a minimum, the model identification and serial number of the fireplace inspected, the location where the model was inspected, the names of the manufacturer's and/or builder's representatives present, the date of inspection, and a description of any changes made to the approved fireplace model line or design since the last inspection. The U. S. EPA accredited laboratory which conducts the annual quality control inspection is responsible for auditing the content and format of all labels to be applied to approved fireplaces as stipulated in 31.209.

A fireplace model line or design shall be re-tested in accordance with Section 31.202 if it is determined during inspection that design changes have been incorporated into the approved/certified fireplace design which adversely affect the fireplace particulate emissions factor. Design elements which can affect fireplace particulate emissions include:

1. Grate placement and height;
2. Air supply minimum and maximum controls;
3. Usable hearth area; and
4. Firebox height, width, and length dimensions.

**SECTION 31.209 — PERMANENT LABEL, TEMPORARY LABEL AND OWNER'S MANUAL.**

**31.209.1 Labels and the Owner's Manual.** Labels and owner's manual shall be prepared and installed in all certified "For Sale" fireplaces as specified in U. S. EPA 40 CFR Part 60, Section 60.536. Information that shall be presented on all labels includes:

1. Manufacturer's or Builder's name, address, and phone number;
2. Model number and/or name;
3. Month and year of manufacture;
4. Starting and ending dates for the 5-year approval period;
5. If a fireplace was tested and approved with an emissions control device which is not an integral part of the fireplace structure, the label shall state that "The fireplace cannot be sold or installed without the specified emissions control device in place and operational.";
6. On certified fireplaces the statement: "This appliance has been tested and has demonstrated compliance with Washington State amendment to the UBC Standard, Chapter 31-2 requirements."

**SECTION 31.210 — LIST OF APPROVED FIREPLACES.**

DOE shall maintain a list of approved fireplace model lines and designs, and that list shall be available to the public.



**APPENDIX M**  
**INTERNATIONAL EXISTING BUILDING CODE, 2006 EDITION**

**101.4 Applicability.** When requested by the permit applicant, this code shall apply to the repair, alteration, change of occupancy and relocation of buildings existing on the date of adoption of this code, regardless of occupancy, subject to the criteria of Sections 101.4.1 and 101.4.2. When compliance with this code has not been requested, compliance with the International Building, Fire and Mechanical Codes (as applicable) shall be demonstrated.

**101.4.2 Buildings previously occupied.** The legal occupancy of any building existing on the date of adoption of this code shall be permitted to continue without change, except as is specifically covered in this code, the International Fire Code, or the International Property Maintenance Code, or as deemed necessary by the code official to mitigate an unsafe building. For the purpose of this section, "unsafe building" is not to be construed as mere lack of compliance with the current code.

**101.5 Compliance methods.** The repair, alteration, change of occupancy, addition or relocation of all existing buildings shall comply with one of the methods listed in Sections 101.5.1 through 101.5.3 as selected by the applicant. Application of a method shall be the sole basis for assessing the compliance of work performed under a single permit unless otherwise approved by the code official. Sections 101.5.1 through 101.5.3 shall not be applied in combination with each other.

**Exception:** Subject to the approval of the code official, alterations complying with the laws in existence at the time the building or the affected portion of the building was built shall be considered in compliance with the provisions of this code unless the building is undergoing more than a limited structural alteration as defined in Section 807.5.3. New structural members added as part of the alteration shall comply with the International Building Code. Alterations of existing buildings in flood hazard areas shall comply with Section 601.3.

**101.7 Appendices.** The code official is authorized to require rehabilitation and retrofit of buildings, structures, or individual structural members in accordance with the appendices of this code if such appendices have been individually adopted. Where Appendix A, Guidelines for the Seismic Retrofit of Existing Buildings, is specifically referenced in the text of this code, it becomes part of this code without any specific adoption by the local jurisdiction.

**102.4.1 Fire prevention.** The provisions of the International Fire Code shall apply to matters affecting or relating to structures, processes and premises from the hazard of fire and explosion arising from the storage, handling or use of structures, materials or devices; from conditions hazardous to life, property or public welfare in the occupancy of structures or premises; and from the construction, extension, repair, alteration or removal of fire suppression and alarm systems or fire hazards in the structure or on the premises from occupancy or operation except as specifically provided for in this code.

(Insert Facing Page 1)



**302.1 Existing buildings or structures.** Additions or alterations to any building or structure shall comply with the requirements of the *International Building Code* for new construction except as specifically provided in this code. Additions or alterations shall not be made to an existing building or structure that will cause the existing building or structure to be in violation of any provisions of the *International Building Code*. An existing building plus additions shall comply with the height and area provisions of the *International Building Code*. Portions of the structure not altered and not affected by the alteration are not required to comply with the code requirements for a new structure.



**[B] 305.1 Conformance.** No change shall be made in the use or occupancy of any building that would place the building in a different division of the same group of occupancy or in a different group of occupancies, unless such building is made to comply with the requirements of the *International Building Code* for such division or group of occupancy. Subject to the approval of the building official, the use or occupancy of existing buildings shall be permitted to be changed and the building is allowed to be occupied for purposes in other groups without conforming to all the requirements of the *International Building Code* for those groups, provided the new or proposed use is less hazardous, based on life and fire risk, than the existing use. The hazard tables of Chapter 9 may be used to demonstrate the relative fire and life risk of the existing and the new proposed uses.

I



**405.1 Scope.** Level 3 alterations apply where the work area exceeds 50% of the floor area of the building.



**(Insert Facing Page 19)**



**506.1.1.2 IBC level seismic forces.** When seismic forces are required to meet the *International Building Code* level, they shall be one of the following:

1. One hundred percent of the values in the *International Building Code*. The *R*-factor used for analysis in accordance with Chapter 16 of the *International Building Code* shall be the *R*-factor specified for structural systems classified as "ordinary" in accordance with Table 12.2-1 of ASCE 7, unless it can be demonstrated that the structural system satisfies the proportioning and detailing requirements for systems classified as "intermediate" or "special."
2. Those associated with the BSE-1 and BSE-2 Earthquake Hazard Levels defined in ASCE 41. Where ASCE 41 is used, the corresponding performance levels shall be those shown in Table 506.1.1.2.

**TABLE 506.1.1.2  
ASCE 41 AND ASCE 31 PERFORMANCE LEVELS**

OCCUPANCY CATEGORY (BASED ON IBC TABLE 1604.5)	PERFORMANCE LEVEL FOR USE WITH ASCE 31 AND WITH ASCE 41 BSE-1 EARTHQUAKE HAZARD LEVEL	PERFORMANCE LEVEL FOR USE WITH ASCE 41 BSE-2 EARTHQUAKE HAZARD LEVEL
I	Life Safety (LS)	Collapse Prevention (CP)
II	Life Safety (LS)	Collapse Prevention (CP)
III	Note a	Note a
IV	Immediate Occupancy (IO)	Life Safety (LS)

a. Performance levels for Occupancy Category III shall be taken as halfway between the performance levels specified for Occupancy Category II and IV. Where seismic forces are permitted to meet reduced *International Building Code* levels, the performance level for Occupancy Category III shall be Life Safety (LS). Where seismic forces are required to meet the *International Building Code* levels, performance levels for Occupancy Category III shall be taken as follows: Acceptance criteria shall be taken as twenty-five percent more restrictive than the acceptance criteria specified for Occupancy Category II performance levels, but need not be more restrictive than the acceptance criteria specified for Occupancy Category IV performance levels.

(Insert Facing Page 21)

**506.1.1.3 Reduced IBC level seismic forces.** When seismic forces are permitted to meet reduced *International Building Code* levels, they shall be one of the following:

1. Seventy-five percent of the forces prescribed in the *International Building Code*. The *R*-factor used for analysis in accordance with Chapter 16 of the *International Building Code* shall be the *R*-factor as specified in Section 506.1.1.2 of this code.
2. In accordance with the applicable chapters in Appendix A of this code as specified in Items 2.1 through 2.5 below. Structures or portions of structures that comply with the requirements of the applicable chapter in Appendix A shall be deemed to comply with the requirements for reduced *International Building Code* force levels.
  - 2.1. The seismic evaluation and design of unreinforced masonry bearing wall buildings in Occupancy Category I or II are permitted to be based on the procedures specified in Appendix Chapter A1.
  - 2.2. Seismic evaluation and design of the wall anchorage system in reinforced concrete and reinforced masonry wall buildings with flexible diaphragms in Occupancy Category I or II are permitted to be based on the procedures specified in Appendix Chapter A2.
  - 2.3. Seismic evaluation and design of cripple walls and sill plate anchorage in residential buildings of light-frame wood construction in Occupancy Category I or II are permitted to be based on the procedures specified in Appendix Chapter A3.
  - 2.4. Seismic evaluation and design of soft, weak or open-front wall conditions in multiunit residential buildings of wood construction in Occupancy Category I or II are permitted to be based on the procedures specified in Appendix Chapter A4.
  - 2.5. Seismic evaluation and design of concrete buildings and concrete with masonry infill buildings in all occupancy categories are permitted to be based on the procedures specified in Appendix Chapter A5.
3. In accordance with ASCE 31 based on the applicable performance level as shown in Table 506.1.1.2.
4. Those associated with the BSE-1 Earthquake Hazard Level defined in ASCE 41 and the performance level as shown in Table 506.1.1.2. Where ASCE 41 is used, the design spectral response acceleration parameters  $S_{XS}$  and  $S_{XI}$  shall not be taken less than seventy-five percent of the respective design spectral response acceleration parameters  $S_{DS}$  and  $S_{DI}$  defined by the *International Building Code* and its reference standards.

(Insert Facing Page 22)





**704.1 Scope.** The requirements of this section shall be limited to work areas in which Level 2 alterations are being performed, and where specified they shall apply throughout the floor on which the work areas are located or otherwise beyond the work area.

**Exception:** For Level 2 alteration projects in which the fire protection requirements constitute an excessive burden, the fire protection requirements may be modified or waived by the fire code official.

**704.2 Automatic sprinkler systems.** Automatic sprinkler systems shall be provided in accordance with the requirements of Sections 704.2.1 through 704.2.5. Installation requirements shall be in accordance with the International Fire Code and NFPA 13 or NFPA 13R.

**(Insert Facing Page 31)**



**807.5.1 Evaluation and analysis.** An engineering evaluation and analysis that establishes the structural adequacy of the altered structure shall be prepared by a registered design professional and submitted to the code official. For structures assigned to Seismic Design Category D, the registered design professional shall submit to the code official a seismic evaluation report of the existing building based on one of the procedures specified in Section 506.1.1.3. This seismic evaluation report shall not be required for buildings in compliance with the benchmark building provisions of ASCE 31, Section 3.2.

**807.5.2 Substantial structural alteration.** Any building or structure undergoing substantial improvement shall have an evaluation and analysis to demonstrate that the altered building or structure complies with the *International Building Code* for wind loading and with reduced *International Building Code* level seismic forces as specified in Section 507.1.1.3 for seismic loading. For seismic considerations, the analysis shall be based on one of the procedures specified in Section

⇒ 507.1.1.1.

**807.5.3 Limited structural alteration.** Where any building or structure undergoes less than substantial improvement, the evaluation and analysis shall demonstrate that the altered building or structure complies with the loads applicable at the time the building was constructed.

⇒



**912.1.1 Compliance with Chapter 8.** The requirements of Chapter 8 shall be applicable throughout the building for the new occupancy classification based on the separation conditions set forth in Sections 912.1.1.1 and 912.1.1.2. All existing buildings with a change of occupancy classification shall comply with the seismic provisions of Section 907.3.

(Insert Facing Page 45)



**1101.1 Scope.** It is the intent of this chapter to provide means for the preservation of historic buildings as defined in Chapter 2. It is the purpose of this chapter to encourage cost-effective preservation of original or restored architectural elements and features and to provide a historic building that will result in a reasonable degree of safety, based on accepted life and fire safety practices, compared to the existing building. Historical buildings shall comply with the provisions of this chapter relating to their repair, alteration, relocation and change of occupancy.

**1101.2 Report.** A historic building undergoing repair, alteration, or change of occupancy shall be investigated and evaluated. If it is intended that the building meet the requirements of this chapter, a written report shall be prepared and filed with the code official by a registered design professional when such a report is necessary in the opinion of the code official. Such report shall be in accordance with Chapter 1 and shall identify each required safety feature that is in compliance with this chapter and where compliance with other chapters of these provisions would be damaging to the contributing historic features. In Seismic Design Category D or higher, a structural evaluation describing, at minimum, a complete load path and other earthquake-resistant features shall be prepared. In addition, the report shall describe each feature that is not in compliance with these provisions and shall demonstrate how the intent of these provisions is complied with in providing an equivalent level of safety.

**1102.4 Chapter 5 compliance.** Historic buildings undergoing repairs shall comply with all of the applicable requirements of Chapter 5, except as specifically permitted in this chapter.

**1102.5 Replacement.** Replacement of existing or missing features using original materials shall be permitted. Partial replacement for repairs that match the original in configuration, height, and size shall be permitted. Such replacements shall not be required to meet the materials and methods requirements of Section 501.2.

**Exception:** Replacement glazing in hazardous locations shall comply with the safety glazing requirements of Chapter 24 of the *International Building Code*.

**1104.1 Accessibility requirements.** The provisions of Section 605 shall apply to buildings and facilities designated as historic structures that undergo alterations, unless technically infeasible. Where compliance with the requirements for accessible routes, ramps, entrances, or toilet facilities would threaten or destroy the historic significance of the building or facility, as determined by the professional responsible for the historical documentation of the project, the alternative requirements of Sections 1104.1.1 through 1104.1.4 for that element shall be permitted.

**1103.7 One-hour fire-resistant assemblies.** Where one-hour fire-resistance-rated construction is required by these provisions, it need not be provided, regardless of construction or occupancy, where the existing wall and ceiling finish is wood lath or metal lath and plaster.

**1103.9 Stairway railings.** Historically significant stairways shall be accepted without complying with the handrail and guard requirements. Existing handrails and guards at all stairs shall be permitted to remain, provided they are not structurally dangerous.

(Insert Facing Page 52)

**1105.14 Natural light.** When it is determined by the professional responsible for the historical documentation of the project that compliance with the natural light requirements of Section 911.1 will lead to loss of historic character or historic materials in the building, the existing level of natural lighting shall be considered acceptable.

**1106.1 General.** Historic buildings shall comply with the applicable structural provisions for the work as classified in Chapter 5.

**Exception:** The code official shall be authorized to accept existing floors and approve operational controls that limit the live load on any such floor.

**1105.10 One-hour fire-resistant assemblies.** Where one-hour fire-resistance-rated construction is required by these provisions, it need not be provided, regardless of construction or occupancy, where the existing wall and ceiling finish is wood lath or metal lath and plaster.



(Insert Facing Page 57)

**1301.4.1 Structural analysis.** The owner shall have a structural analysis of the existing building made to determine adequacy of structural systems for the proposed alteration, addition, or change of occupancy. The analysis shall demonstrate that the altered building or structure complies with the requirements of Chapter 16 of the *International Building Code*.

**Exception:** The reduced *International Building Code* level seismic forces as specified in Section 506.1.1.3 shall be permitted to be used for this analysis.



**ASCE**

American Society of Civil Engineers  
1801 Alexander Bell Drive  
Reston, VA 20191-4400

---

Standard reference number	Title	Referenced in code section number
7-05	Minimum Design Loads for Buildings and Other Structures with Supplement No. 1 .....	506.1.1.2
31-03	Seismic Evaluation of Existing Buildings.....	506.1.1.1, Table 506.1.1.2, 506.1.1.3
41-06	Seismic Rehabilitation of Existing Buildings .....	506.1.11, Table 506.1.1.2, 506.1.1.3



National Fire Protection Association  
1 Batterymarch Park  
Quincy, MA 02269-9101

Standard reference number	Title	Referenced in code section number
NFPA 13—02	Installation of Sprinkler Systems .....	704.2
NFPA 13R—99	Installation of Sprinkler Systems in Residential Occupancies up to and Including Four Stories in Height .....	604.2.5, 704.2
NFPA 70—05	National Electrical Code .....	507.1.1, 507.1.2, 507.1.3, 507.1.4, 507.1.5
NFPA 72—99	National Fire Alarm Code.....	704.2.5, 704.4
NFPA 99—99	Health Care Facilities.....	507.1.4
NFPA 101—03	Life Safety Code .....	705.2

(Insert Facing Page 72)